

Masoneilan™ 84003 Series SteamForm™

Steam Conditioning Valves

Excellent noise control, temperature control, and fast operation while maintaining smooth flow control and reliable shut-off.



Table of Contents

Features and Benefits	3
General Data	4
Numbering System	4
Seal Types	5-6
Trim Types	7
Optional Configuration	8
Body S/A Construction	8
Materials of Construction	9
84003 Series Configurations	10-11

Features and Benefits

Applications

Steam conditioning requirements vary across every industry. Process plants, for example, require steady operation and precise temperature control, while Power plants rely on fast response and low noise emittance. Masoneilan SteamForm valves serve the entire range of steam conditioning, offering excellent noise control, temperature control, and fast operation while maintaining smooth flow control and reliable shut-off.

The Masoneilan SteamForm valves combines over 25 years of proven pressure reducing performance with a robust desuperheating design. Available with a wide selection of performance enhancing configurations, Baker Hughes offers the Best Fit solution for virtually every steam conditioning application. Each SteamForm valve solution provided by Baker Hughes is custom designed by an experienced engineering team to meet specific customer requirements. Masoneilan Steam Conditioning valves are designed using only robust and proven technology, materials, quality control practices, and manufacturing methods. The technology and material combinations used in the SteamForm are based on over 50 years of successful field experience in various industries.

Various Trim Types and Seal Options

The 84003 Series is available with a variety of trim types and seal designs to meet all requirements for shut-off, pressure/temperature regulation, and noise.

High Rangeability with up to 50:1 Turndown

Many applications use steam conditioning valves to throttle across a wide range of operating conditions. An example of this is turbine bypass, which often requires low-flow control for regulating pressure during startup, and high-flow capacity for full load rejection. Some applications require flow rangeability up to 50:1. For these applications, Baker Hughes engineers optimize the lift characteristic and pressure staging to ensure excellent control and performance at low-flow conditions.

Fast Response and Precision Control

The 84003 Series SteamForm Valves can be equipped with a rapid stroke actuator, capable of achieving full opening and/or closing in less than 1 second. This is a critical feature, necessary for protecting plant equipment during an upset condition, such as a turbine trip. Masoneilan actuators are equipped with a Masoneilan SVI™ II AP digital positioner, which provides best-in-class control accuracy and response.

General Data

Body Configurations:	Globe / Angle / Custom Offset (Z Body)
Seat Diameter:	50 mm (2 in.) to 600 mm (24 in.)
Rated Cv:	Up to 5800
Connections:	Butt Weld, RFF, RTJ, Socket Weld
Pressure Class Ratings:	Up to ASME Class 4500, Special and Intermediate (job rated)
Temperature:	Up to 650°C (1200°F)
Applicable Codes / Standards:	ASME B16.34 / B31.1 / B31.3, PED, GOST, SIL3, CRN, IBR, ISO9001
Actuator Types:	Pneumatic or Hydraulic

Numbering System

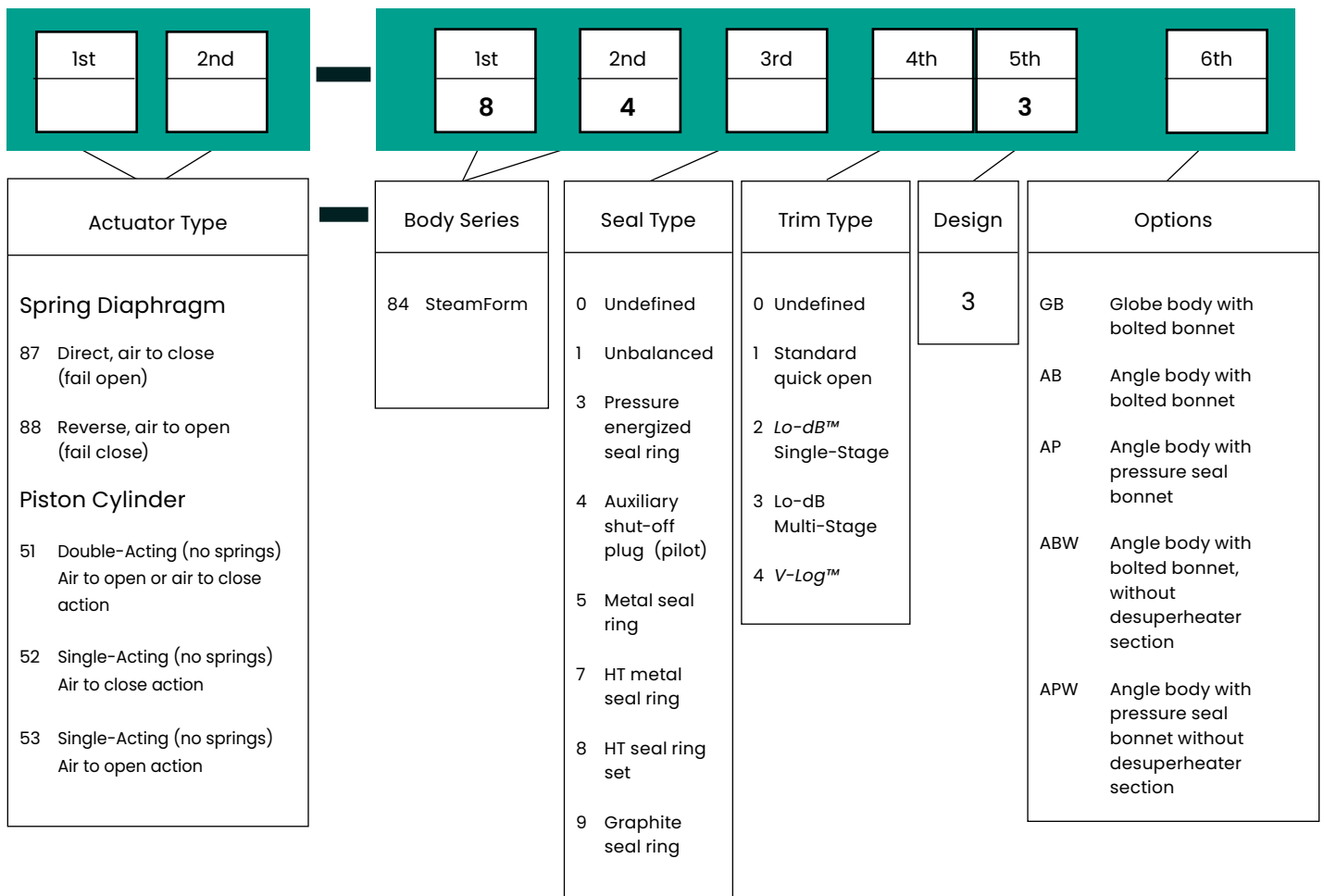

84003 Series Seal Types

Seal Type (3rd Designation In Numbering System)

Designation	Seal Type	Description	Rated Leakage	Flow Direction	Design Temperature Range	Design Pressure Range	Pressure Class Range
0	Undefined	Custom Engineered / Non-Standard	As Engineered	As Engineered	As Engineered	Up to 776 Bar (1125 psig)	As Engineered
1	Unbalanced	Solid Plug, Relies Only on Main Seat For Valve Closure. Radial Seal Ring May Be Used For Plug Stability	Class V	FTO or FTC	38°C (100°F) - 648°C (1200°F)	Up to 776 Bar (11250 psig)	150-4500
3	Pressure Energized Seal Ring	Balanced Plug With High Temperature Radial Polymer Seal	Class V	FTO or FTC	38°C (100°F) - 316°C (600°F)	Up to 776 Bar (11250 psig)	150-2500
4	Auxiliary Shut-Off Plug (Pilot)	Balanced Plug With Pilot	Class V	FTC	38°C (100°F) - 607°C (1125°F)	Up to 431 Bar (6250 psig)	150-4500
5	Metal Seal Ring	Balanced Plug With Metal Seal	Class III	FTO or FTC	38°C (100°F) - 566°C (1050°F)	Up to 431 Bar (6250 psig)	150-2500
7	HT Metal Seal Ring	Balanced Plug With Metal Compression Radial Seal	Class V	FTO or FTC	38°C (100°F) - 427°C (800°F)	Up to 431 Bar (6250 psig)	150-2500
8	HT Seal Ring Set	Balanced Plug With Precision Metal & Graphite Radial Seal	Class IV	FTO or FTC	38°C (100°F) - 573°C (1065°F)	Up to 431 Bar (6250 psig)	150-2500
9	Graphite Seal Ring	Balanced Plug With Graphite Radial Seal	Class IV	FTO or FTC	38°C (100°F) - 427°C (800°F)	Up to 431 Bar (6250 psig)	150-2500

84003 Series Seal Types



Seal Type 1

Seal Type: Unbalanced
Leakage: Class V
Flow Action: FTO or FTC
Temperature: 648°C (1200°F)



Seal Type 3

Seal Type: Pressure Energized
Leakage: Class V
Flow Action: FTO or FTC
Temperature: 316°C (600°F)



Seal Type 4

Seal Type: Auxiliary Shut-Off (Pilot)
Leakage: Class V
Flow Action: FTC
Temperature: 607°C (1125°F)



Seal Type 5

Seal Type: Metal Seal
Leakage: Class III
Flow Action: FTO or FTC
Temperature: 566°C (1050°F)



Seal Type 7

Seal Type: High Temperature Metal Seal
Leakage: Class V
Flow Action: FTO or FTC
Temperature: 427°C (800°F)



Seal Type 8

Seal Type: Precision Ring Set
Leakage: Class IV
Flow Action: FTO or FTC
Temperature: 573°C (1065°F)



Seal Type 9

Seal Type: Graphite Seal
Leakage: Class IV
Flow Action: FTO or FTC
Temperature: 427°C (800°F)

84003 Series Trim Types

Trim Type (4th designation in numbering system)

Designation	Trim Type	Description	Available Flow Directions
0	Undefined	Custom Engineered / Non-Standard	FTO or FTC
1	Standard Quick Open	Basic ON/OFF Function With No Control Element	FTC only
2	Lo-dB Single-Stage	Drilled Hole Cage With No Diffusers	FTO or FTC
3	Lo-dB Multi-Stage	Drilled Hole Cage With Diffuser(s)	FTO or FTC
4	V-Log	Disk Stack Cage With Tortuous Flow Channels	FTO only

FLOW TO CLOSE

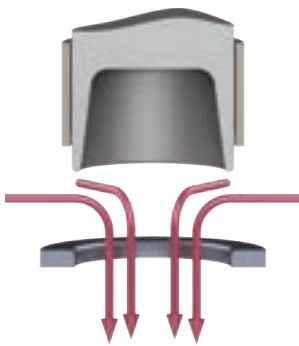

Trim Type 1

Trim Type: Standard Quick Open
Description: No Controlling Element, On/ Off Function.

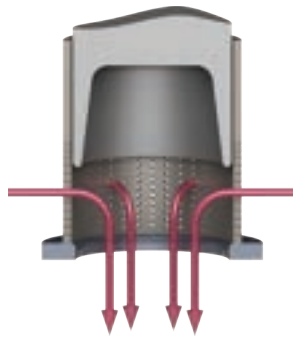

Trim Type 2

Trim Type: Lo-dB Single-Stage
Description: Control and noise reduction is achieved through a single drilled hole cage.

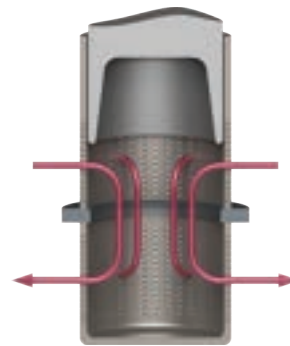

Trim Type 3 (AB)

Trim Type: Lo-dB Multi-Stage
Description: Control and noise is achieved through a single drilled hole cage, and additional diffusers are added downstream of the seat to further reduce noise.

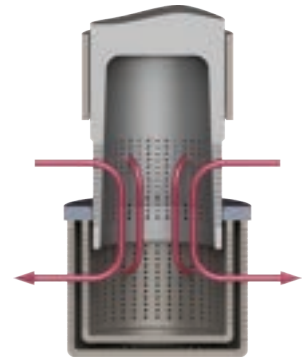

Trim Type 3 (AP)

Trim Type: Lo-dB Multi-Stage
Description: Control and noise is achieved through a drilled hole plug skirt, and additional diffusers are added downstream of the seat to further reduce noise.

FLOW TO OPEN

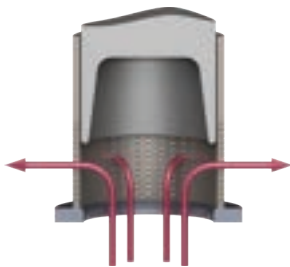

Trim Type 2

Trim Type: Lo-dB Single-Stage
Description: Control and noise reduction is achieved through a single removable cage.

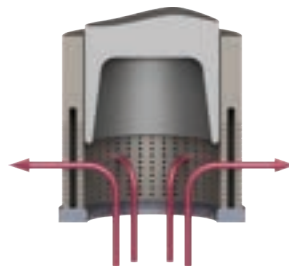

Trim Type 3

Trim Type: Lo-dB Multi-Stage
Description: Control and noise reduction is achieved through a Multi-Stage cage.

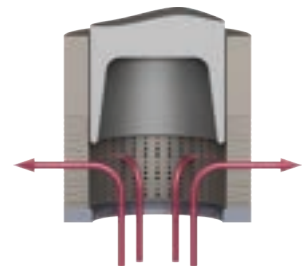

Trim Type 3

Trim Type: V-Log
Description: Control and noise reduction is achieved through a stack of precision machined plates, which create a tortuous flow path.

84003 Series Optional Configuration

Optional Configuration (6th designation in numbering system)

Designation	Optional Configuration	Available Flow Direction	Temperature Range	Pressure Class Range	Design Pressure Range
GB	Globe Body with Bolted Bonnet	FTC or FTO	38°C (100°F) - 566°C (1050°F)	150-2500	0 - 430 barg / (0 - 6250 psig)
AB	Angle Body with Bolted Bonnet	FTC or FTO	38°C (100°F) - 648°C (1200°F)	150-4500	0 - 775 barg / (0 - 11250 psig)
AP	Angle Body with Pressure Seal Bonnet	FTC only	38°C (100°F) - 607°C (1125°F)	600-2500	69 - 430 barg / (1000 - 6250 psig)
ABW	Angle Body with Bolted Bonnet, without Desuperheater Section	FTC only	38°C (100°F) - 648°C (1200°F)	150-4500	0 - 775 barg / (0 - 11250 psig)
APW	Angle Body with Pressure Seal Bonnet, without Desuperheater Section	FTC only	38°C (100°F) - 607°C (1125°F)	600-2500	69 - 430 barg / (1000 - 6250 psig)

84003 Series Body S/A Construction

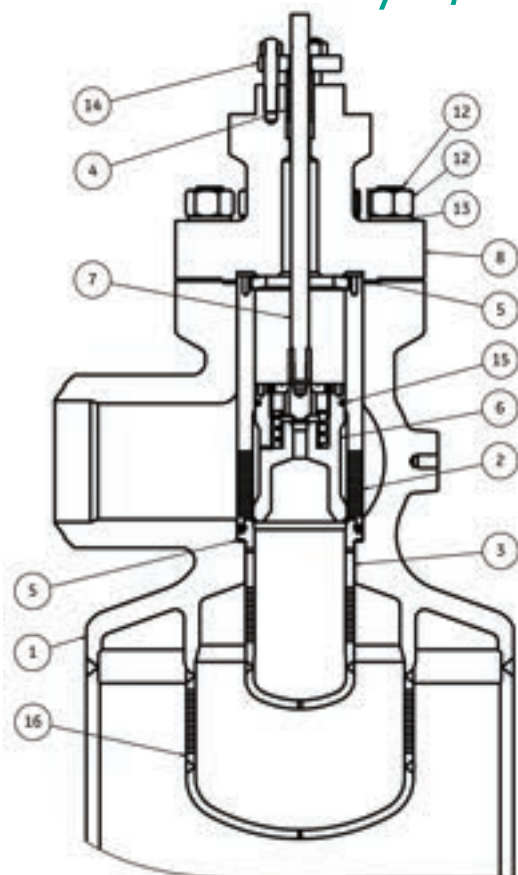

Bolted Bonnet Design (-84433AB)

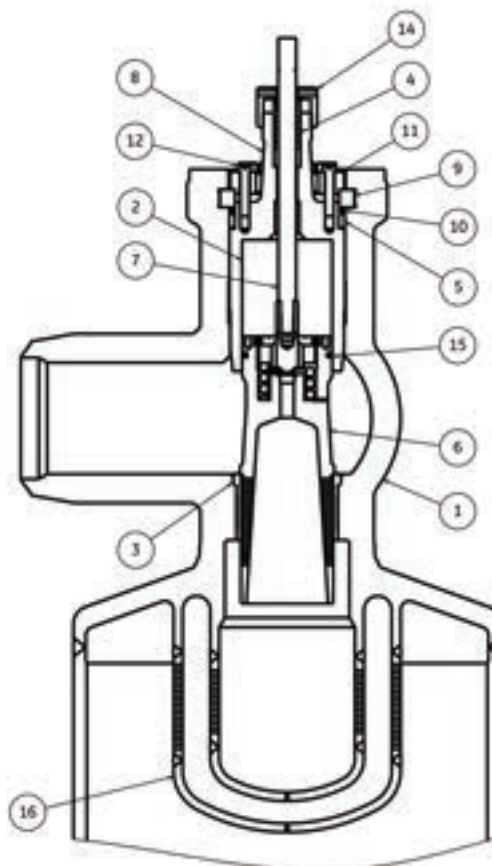

Pressure Seal Bonnet Design (-84433AP)

84003 Series Materials of Construction

ITEM	PART DESCRIPTION	TEMPERATURE LIMIT	MATERIALS OF CONSTRUCTION
1	BODY	427°C (800°F)	Carbon Steel
		510°C (950°F)	1-1/4Cr 1/2Mo
		565°C (1050°F)	2-1/4Cr 1Mo
		649°C (1200°F)	9Cr 1Mo V
		649°C (1200°F)	9Cr 1/2Mo 1-3/4W
2	CAGE	510°C (950°F)	ASTM A487 Gr CA6NM + NITRIDING
		565°C (1050°F)	ASTM A182 Gr F22 + NITRIDING
		607°C (1125°F)	ASTM A182 Gr F91 + NITRIDING
		649°C (1200°F)	ASTM A182 Gr F91 + NITRIDING+ HVOF
3	SEAT	343°C (650°F)	17-4 PH STAINLESS STEEL
		510°C (950°F)	ASTM A487 Gr CA6NM + STELLITE HF SEAT
		649°C (1200°F)	ASTM A182 Gr F91 + STELLITE HF SEAT
		427°C (800°F)	CARBON STEEL
		510°C (950°F)	1-1/4Cr 1/2Mo
		565°C (1050°F)	2-1/4Cr 1Mo
		649°C (1200°F)	9Cr 1Mo V
		649°C (1200°F)	9Cr 1/2Mo 1-3/4W
		649°C (1200°F)	STELLITE 6
4	PACKING	649°C (1200°F)	GRAPHITE
5	GASKETS / PRESSURE SEAL	510°C (950°F)	316L + GRAPHITE
		649°C (1200°F)	INCONEL + GRAPHITE
		649°C (1200°F)	GRAPHITE with STAINLESS CAPS (PSB)
6	MAIN PLUG ¹	343°C (650°F)	17-4 PH STAINLESS STEEL
		510°C (950°F)	ASTM A182 Gr F6NM + NITRIDING
		510°C (950°F)	ASTM A182 Gr F6NM + STELLITE HF SEAT + NITRIDING
		565°C (1050°F)	ASTM A182 Gr F22 + NITRIDING
		565°C (1050°F)	ASTM A182 Gr F22 + STELLITE HF SEAT + NITRIDING
		607°C (1125°F)	ASTM A182 Gr F91 + NITRIDING
		607°C (1125°F)	ASTM A182 Gr F91 + STELLITE HF SEAT + NITRIDING
		649°C (1200°F)	ASTM A182 Gr F91 + STELLITE HF SEAT & GUIDES
7	STEM	343°C (650°F)	17-4 PH STAINLESS STEEL
		510°C (950°F)	ASTM A38 GR 660
		649°C (1200°F)	ASTM B637 N07718
8	BONNET	427°C (800°F)	ASTM A 216 Gr WCC or ASTM A105
		510°C (950°F)	ASTM A 217 Gr WC6 or ASTM A182 Gr F11
		565°C (1050°F)	ASTM A 217 Gr WC9 or ASTM A182 Gr F22
		649°C (1200°F)	ASTM A 217 Gr C12A or ASTM A182 Gr F91
9	SEAL RETAINER	427°C (800°F)	ASTM A 216 Gr WCC or ASTM A105
		649°C (1200°F)	ASTM A 217 Gr C12A or ASTM A182 Gr F91
10	BACKUP RING	649°C (1200°F)	ASTM A 479 TYPE 316
11	COMPRESSION FLANGE	427°C (800°F)	ASTM A 216 Gr WCC or ASTM A105
		649°C (1200°F)	ASTM A 217 Gr WC9 or ASTM A182 Gr F22
12	BODY BOLT / NUT	427°C (800°F)	ASTM A193 Gr B7 / ASTM A194 2H
		510°C (950°F)	ASTM A193 Gr B16 / ASTM A194 Gr 4 or ASTM A194 Gr 7
		649°C (1200°F)	ASTM B637 N07718 / ASTM A194 Gr 8
13	BODY BOLT WASHER	649°C (1200°F)	HARDENED 440C STAINLESS STEEL
14	GUIDE BUSHING	649°C (1200°F)	STELLITE 6
	PACKING FOLLOWER	649°C (1200°F)	ASTM A 479 TYPE 316
	PACKING FLANGE	649°C (1200°F)	ASTM A 479 TYPE 316
	PACKING BOLT	649°C (1200°F)	ASTM A 193 Gr B8
	PACKING NUT	649°C (1200°F)	ASTM A194 Gr 8
15	PACKING COLLAR	649°C (1200°F)	ASTM A 479 TYPE 316
15	PLUG SEAL RING ²	316°C (600°F)	FLOUROLOY
		454°C (850°F)	GRAPHITE
		607°C (1125°F)	ASTM A182 Gr CA6NM + NITRIDING
		649°C (1200°F)	STELLITE 6 or STELLITE 21
16	WELDED DIFFUSER (S)	427°C (800°F)	ASTM A 106 Gr B or ASTM A105
		510°C (950°F)	ASTM A335 Gr P11 or ASTM A182 Gr F11
		565°C (1050°F)	ASTM A335 Gr P22 or ASTM A182 Gr F22
		649°C (1200°F)	ASTM A335 Gr P91 or ASTM A182 Gr F91

Notes:

1. Main Plug - materials apply for all seal types.
2. Plug Seal Ring - options are dependent on the seal type.

84003 Series Configurations

88-84423GB
Globe Body with Bolted Bonnet,
Pilot Balanced Plug,
Flow To Close.



51-84433AB
Angle Body with Bolted Bonnet,
Pilot Balanced Plug,
Flow To Close.



51-84433AP
Angle Body with Pressure Seal Bonnet,
Pilot Balanced Plug,
Flow To Close.

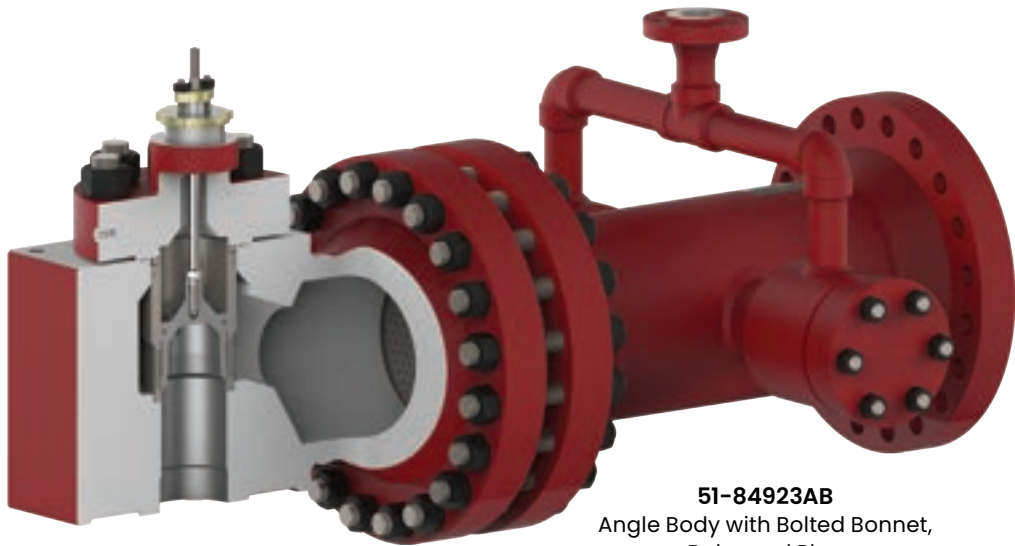

51-84923AB
 Angle Body with Bolted Bonnet,
 Balanced Plug,
 Flow To Open.

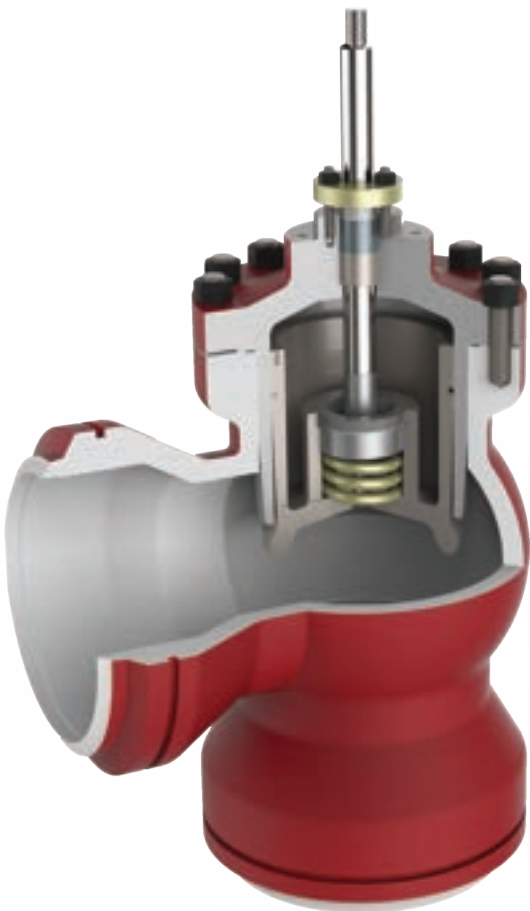

53-84413ABW
 Angle Body with Bolted Bonnet,
 Pilot Balanced Plug,
 Flow To Close.

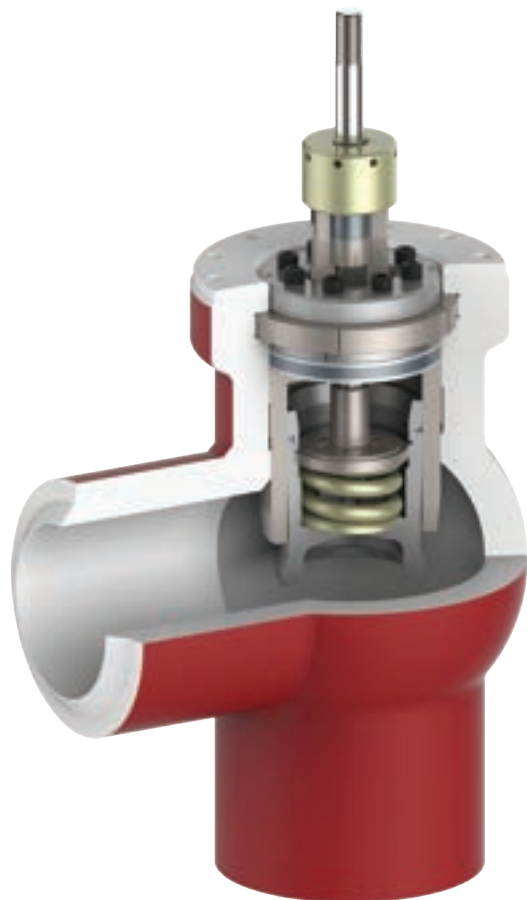

88-84413APW
 Angle Body with Pressure Seal Bonnet,
 Pilot Balanced Plug,
 Flow To Close.

Direct Sales Office Locations

Australia

Brisbane
Phone: +61-7-3001-4319

Perth
Phone: +61-8-6595-7018

Melbourne
Phone: +61-3-8807-6002

Brazil

Phone: +55-19-2104-6900

China

Phone: +86-10-5738-8888

France

Courbevoie
Phone: +33-1-4904-9000

India

Mumbai
Phone: +91-22-8354790

New Delhi

Phone: +91-11-2-6164175

Italy

Phone: +39-081-7892-111

Japan

Tokyo
Phone: +81-03-6871-9008

Korea

Phone: +82-2-2274-0748

Malaysia

Phone: +60-3-2161-03228

Mexico

Phone: +52-55-3640-5060

Russia

Veliky Novgorod
Phone: +7-8162-55-7898

Moscow

Phone: +7-495-585-1276

Saudi Arabia

Phone: +966-3-341-0278

Singapore

Phone: +65-6861-6100

South Africa

Phone: +27-11-452-1550

South & Central America and the Caribbean

Phone: +55-12-2134-1201

Spain

Phone: +34-935-877-605

United Arab Emirates

Phone: +971-4-8991-777

United Kingdom

Phone: +44-7919-382-156

United States

Houston, Texas

Phone: +1-713-966-3600

Find the nearest local Channel Partner in your area:

valves.bakerhughes.com/contact-us

Tech Field Support & Warranty:

Phone: +1-866-827-5378

valvesupport@bakerhughes.com

valves.bakerhughes.com

Copyright 2021 Baker Hughes Company. All rights reserved. Baker Hughes provides this information on an "as is" basis for general information purposes. Baker Hughes does not make any representation as to the accuracy or completeness of the information and makes no warranties of any kind, specific, implied or oral, to the fullest extent permissible by law, including those of merchantability and fitness for a particular purpose or use. Baker Hughes hereby disclaims any and all liability for any direct, indirect, consequential or special damages, claims for lost profits, or third party claims arising from the use of the information, whether a claim is asserted in contract, tort, or otherwise. Baker Hughes reserves the right to make changes in specifications and features shown herein, or discontinue the product described at any time without notice or obligation. Contact your Baker Hughes representative for the most current information. The Baker Hughes logo and Masoneilan are trademarks of Baker Hughes Company. Other company names and product names used in this document are the registered trademarks or trademarks of their respective owners.

Baker Hughes 