

V0-II & V0-76

VARIABLE ORIFICE DESUPERHEATER



Copes-Vulcan has been providing control valves and desuperheaters for the power, process and nuclear industries since 1903. SPX provides a wide range of valves for the control of pressure, temperature and flow-induced noise in all types of power plants. Products include severe service and general service control valves, variable orifice desuperheaters, Raven™, trim and steam-conditioning valves and nuclear control valves, as well as custom designed specialty valves. Copes-Vulcan is recognized worldwide as a leader in valves for severe and critical service applications. Our strength lies in our ability to provide innovative valve solutions for our customers' application needs.

Finding innovative ways to help the world meet its ever growing demand for power is a key focus for SPX. SPX provides creative solutions the serve global energy markets in a myriad of ways. Our ideas are helping build more efficient power plants and renovate older existing facilities. SPX supplies a wide range of components - from air preheaters to filter systems for nuclear, coal-fired, combined cycle, solar, thermal and geothermal power plants. With operations in over 35 countries, SPX has the global experience and regional presence, products and powerful ideas it takes to help our customers compete more effectively, and more efficiently deliver power to almost any part of the world.

Variable Orifice Desuperheater

Copes-Vulcan's VO Variable Orifice Desuperheater is recognized industry wide as the most versatile desuperheater available. It is easily capable of meeting the most demanding needs for desuperheating in both the power and process industries.

The VO offers extremely fine control and exceptional turndown that is limited only by the rangeability of the coolant control valve itself.

With excellent mixing of vapor and coolant, control is possible throughout the entire operating range to within $2 \pm 5^\circ \text{F}$ ($\pm 2.5^\circ \text{C}$) of the set point which can be as close as 10°F (5°C) above saturation.

The coolant pressure which is required at the inlet to the VO need only be 5 psi (35 kPa) above the pressure of the vapor being desuperheated.

Because virtually all of the desuperheating occurs within the VO body itself, the temperature sensing element can be as close as 14–20' (4–6m) from the desuperheater outlet.

DESCRIPTION AND PRINCIPLE OF OPERATION

The Variable Orifice Desuperheater consists of a body which houses the desuperheater internals. The body incorporates a screwed-in seat over which a cage is located in such a manner that a coolant annulus is created around the seat.

The coolant enters this annulus by means of a branch on the desuperheater body. The plug is free floating but incorporates a spring-loaded button which provides stability to the plug under light load conditions. Incorporated in the top of the cage is a plug stop to limit the amount of travel of the plug.

In service, incoming vapor acts on the underside of the plug, which is weighted in such a manner that a certain amount of the energy in the vapor is used to lift the plug.

Model VO

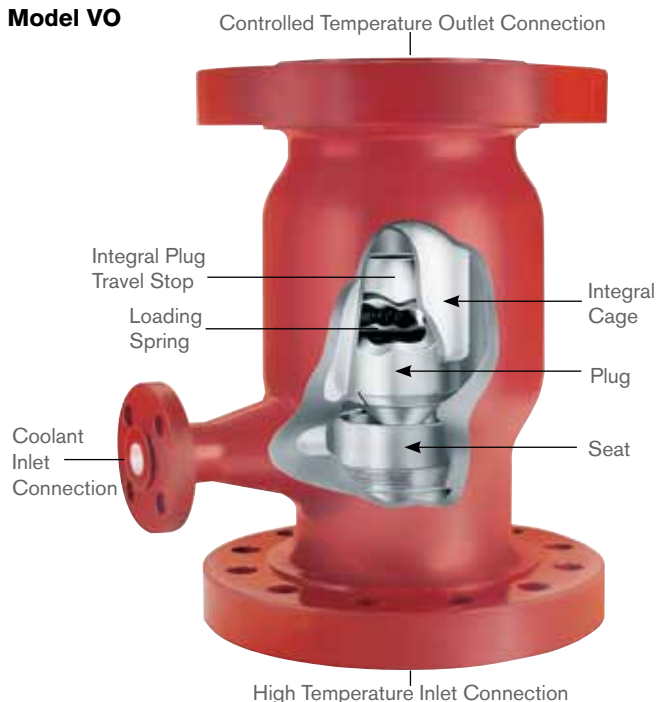

As more vapor flows through the desuperheater, the higher the plug is lifted, thus creating a variable orifice for the vapor flow. The energy used in lifting the plug creates a pressure drop across the seat which is quite constant regardless of the vapor flow. This pressure drop creates a relatively high velocity across the seat area, and it is at this point of low pressure constant velocity that the coolant is admitted into the vapor flow.

Coolant enters the annulus under the dictates of a control valve responsive to a temperature controller sensing the downstream vapor temperature. The coolant is admitted into the vapor flow through a peripheral gap between the underside of the cage and the top of the seat. Coolant is admitted all around the seat, thus ensuring that unequal cooling does not occur.

The coolant is picked up by the vapor flow as it discharges from the seat, and the low pressure zone that exists at this point is instrumental in atomizing the coolant into fine particles. In the turbulence which ensues as a result of the change in direction and velocity of the vapor, intimate mixing of the vapor and coolant takes place. Above the plug, as the vapor attempts to return to laminar flow, a vortex is created and any particles of coolant not completely absorbed by the vapor are drawn into this vortex where they suffer a further pressure reduction which again speeds up the atomizing process.

As virtually all of the desuperheating occurs within the desuperheater body itself, and as no coolant impinges on either the desuperheater or associated piping, no protective thermal liners are required.

INSTALLATION

The desuperheater is designed for installation in a vertical run of pipe with flow upwards. There are no requirements for straight pipe upstream or downstream of the unit, however, if a bend is located immediately at the outlet, it should be a long radius elbow.

Typical product applications

Power Generation

Chemical

Oil & Gas

Pulp & Paper

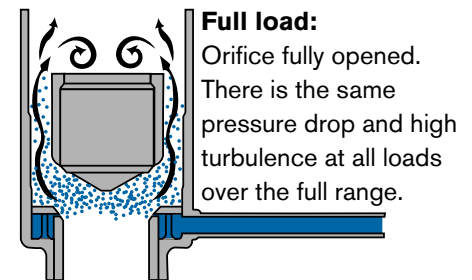
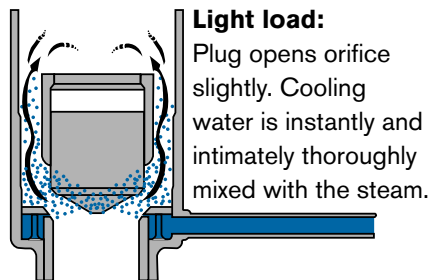
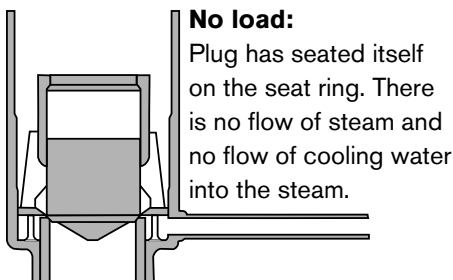
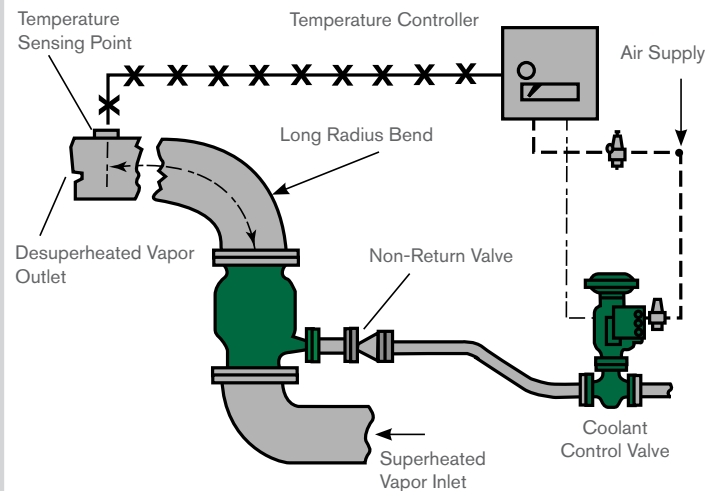

Model VO-II

The basic design of the pressure retaining part of the VO-II is in accordance with ANSI B16.5 (B.S.1560).

Sizes

The VO-II is currently available in sizes 3" (80mm) through 20" (500mm).

Materials of Construction

Carbon steel ASTM A216-WCB

Low allow steel ASTM A217-WC6

Other castable materials available on request.

Pressure Ratings

VO-II desuperheaters are available in ANS pressure classes 150, 300, 600 and 900. For additional sizes, pressure classes, and configurations, refer to Model VO-76.

End Connections

VO-II desuperheaters are normally supplied with flanged connections to ANSI (BS 1560) DIN (BS 4540) or BS10. For additional sizes, end connections, and configurations, refer to Model VO-76.

Sizing/Selection

The VO-II and all Copes-Vulcan desuperheaters can be sized by Copes-Vulcan or an authorized Sales Representative to assure correct application.

Typical information required to size:

- Process steam flow rates
- Process steam pressure
- Process steam temperature (superheated)
- Desired process steam temperature (desuperheated)
- Available cooling water pressure
- Available cooling water temperature
- Process steam line size and schedule

VO-II DIMENSIONS

150/900 Class Rating

UNIT SIZE	NORM. BORE		150/300 RATING			600 RATING			900 RATING		
	A	B	C	D	E	C	D	E	C	D	E
3 (80)	3 (80)	1 (25)	13 (330)	7 (178)	5 (127)	13.75 (349)	7.25 (184)	5.38 (137)	14.25 (362)	7.63 (194)	5.63 (143)
4 (100)	4 (100)	1 (25)	14 (356)	7.5 (191)	5 (127)	15 (381)	7.75 (197)	5.5 (140)	15.5 (394)	8.13 (206)	5.75 (146)
6 (150)	6 (150)	1 (25)	18 (457)	9.63 (244)	6 (152)	19.25 (489)	9.88 (251)	6.63 (168)	20 (508)	10.25 (260)	7 (178)
8 (200)	8 (200)	1 (25)	22 (559)	10.75 (273)	6.5 (165)	23.75 (603)	11 (279)	7.38 (187)	24.25 (616)	11.38 (289)	7.63 (194)
10 (250)	10 (250)	1.5 (40)	27.75 (705)	12.75 (324)	7.75 (197)	29.5 (749)	13 (330)	8.63 (219)	30 (762)	13.38 (340)	8.88 (225)
12 (300)	12 (300)	1.5 (40)	34 (864)	15 (381)	8.75 (222)	35.75 (908)	15.25 (387)	9.63 (244)	36.75 (933)	15.63 (397)	10.13 (257)
14 (350)	14 (350)	1.5 (40)	39.5 (1003)	17 (432)	9 (229)	41.25 (1048)	17.25 (438)	9.88 (251)	42.5 (1079)	17.63 (448)	10.5 (267)
16 (400)	16 (400)	1.5 (40)	43 (1092)	20 (508)	10 (254)	44.5 (1130)	20.25 (514)	10.75 (273)	46 (1168)	20.63 (524)	11.5 (292)
18 (450)	18 (450)	1.5 (40)	50 (1272)	21 (533)	11 (279)	55.25 (1480)	21.25 (540)	12.13 (303)	59.75 (1518)	21.63 (549)	12.88 (327)
20 (500)	20 (500)	2 (50)	—	—	—	—	—	—	—	—	—

Inch
(millimeter)

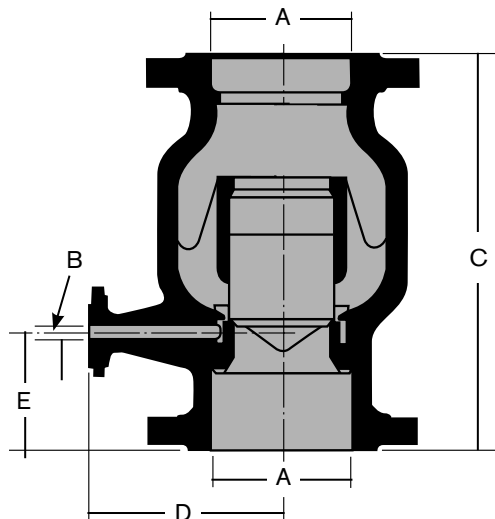

Model VO-76

While virtually identical in operation and performance to the VO-II, the VO-76 is offered by Copes-Vulcan as an alternate when existing piping requires a custom fit, where pressure ratings exceed class 900, or where size requirements exceed those offered in the VO-II.

As "Arrangement #1," the VO-76 housing is supplied as a cast unit with integral inlet flange and butt weld outlet. "Arrangement #2" welds a reducer to the above description. The standard reducer results in a butt weld outlet the same nominal size as the flanged inlet, but non-standard sizes are also available.

As "Arrangement #3," a weld neck flange is added to the combination of housing and reducer. Again, the standard arrangement has the same size inlet and outlet flanges.

By using various sized reducers/expanders and/or flanges, an almost endless variation of dimensions and end connections can be achieved.

The VO-76 is also available with a housing fabricated from forged and wrought piping components when technical specifications and/or N.D.T. requirements preclude the use of castings. Again, reducers and flanges can be added as required, but unlike the cast VO-76, this applies to both inlet and outlet on the fabricated version of the VO-76.

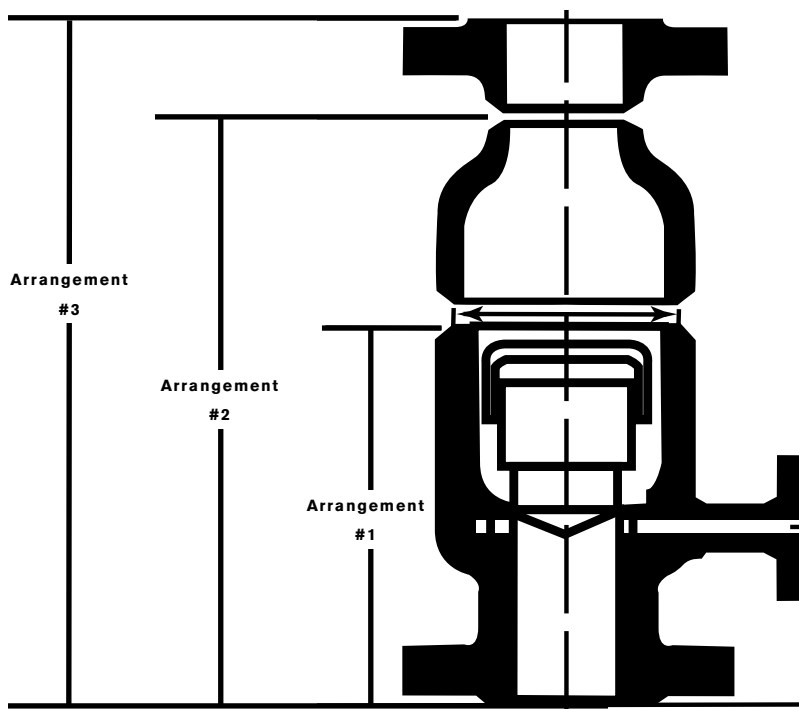

VO-76 Dimensions

ANSI Pressure Classes 150-1500

SIZE	ANSI CLASS	A HOUSING	B HOUSING W/ REDUCER	C HOUSING W/ REDUCER & OUTLET FLANGE	D HOUSING & REDUCER I.D.	E COOLANT FLANGE SIZE	F & G
2 50	150	10.75 (273)	15.75 (400)	18.25 (464)	5 (127)	.75 (19)	
	300	10.75 (273)	15.75 (400)	18.5 (470)			
	400	10.75 (273)	15.75 (400)	18.88 (479)			
	600	10.75 (273)	15.75 (400)	18.88 (479)			
	900	11.5 (292)	16.5 (419)	20.75 (527)			
	1500	11.5 (292)	16.5 (419)	20.75 (527)			
3 75	150	10.75 (273)	16.25 (413)	19 (483)	6 (152)	.75 (19)	
	300	10.75 (273)	16.25 (413)	19.38 (492)			
	400	10.75 (273)	16.25 (413)	19.75 (502)			
	600	10.75 (273)	16.25 (413)	19.75 (502)			
	900	10.75 (273)	16.25 (413)	20.5 (521)			
	1500	12.38 (314)	17.88 (454)	22.75 (578)			
	2500	14 (356)	19.5 (495)	26.38 (670)			
4 100	150	14 (356)	21 (533)	24 (610)	10 (254)	1 (25.4)	
	300	14 (356)	21 (533)	24.38 (619)			
	400	14 (356)	21 (533)	24.75 (629)			
	600	14 (356)	21 (533)	25.25 (641)			
	900	14.5 (368)	21.5 (546)	26.25 (667)			
	1500	15.5 (394)	22.5 (571)	27.63 (702)			
6 150	150	16.5 (419)	24.5 (622)	28 (711)	12 (305)	1.5 (38.1)	
	300	16.5 (419)	24.5 (622)	28.38 (721)			
	400	16.5 (419)	24.5 (622)	28.81 (732)			
	600	16.5 (419)	24.5 (622)	29.38 (746)			
	900	16.5 (419)	24.5 (622)	30.25 (768)			
	1500	19.25 (489)	27.25 (692)	34.25 (870)			
	2500	22.88 (581)	30.88 (784)	39.19 (995)			
8 200	150	20.25 (514)	29.38 (746)	33.38 (848)	14 (356)	2 (50.8)	
	300	20.25 (514)	29.38 (746)	33.75 (857)			
	400	20.25 (514)	29.69 (754)	34.56 (878)			
	600	20.25 (514)	29.69 (754)	35.19 (894)			
	900	20.25 (514)	29.63 (752)	36.25 (921)			
	1500	23.25 (591)	33.38 (848)	42 (1069)			

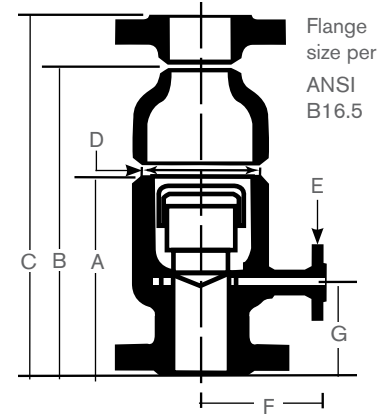

Typical Fabricated Arrangement

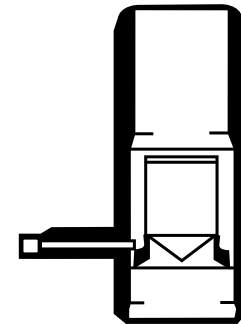

Please contact Copes-Vulcan for F and G dimensions.

A VO-76 typically will be one nominal size smaller than the equivalent VO-II. Both will have the same size plug and internal components.

Request available pressure/temperature ratings and dimensions.

Note: All dimensions are subject to change without notice. Request certified drawings.

Inch
(millimeter)

VO-76 Dimensions (Cont.)

ANSI Pressure Classes 150-1500

SIZE	ANSI CLASS	A HOUSING	B HOUSING W/ REDUCER	C HOUSING W/ REDUCER & OUTLET FLANGE	D HOUSING & REDUCER I.D.	E COOLANT FLANGE SIZE	F & G
10 (250)	150	25.25 (641)	35.19 (894)	39.19 (995)	16 (406)	2.5 (63.5)	
	300	25.25 (641)	35.19 (894)	39.81 (1011)			
	400	25.25 (641)	35.63 (905)	40.75 (1035)			
	600	25.25 (641)	35.63 (905)	41.88 (1064)			
12 (300)	150	29.88 (759)	42.19 (1071)	46.75 (1187)	20 (508)	3 (76.2)	
	300	29.88 (759)	42.19 (1071)	47.38 (1203)			
	400	29.88 (759)	42.69 (1084)	48.38 (1229)			
	600	29.88 (759)	42.69 (1084)	49.13 (1248)			
14 (350)	150	34.13 (867)	47.81 (1214)	52.81 (1341)	24 (610)	3 (76.2)	
	300	34.13 (867)	47.81 (1214)	53.44 (1357)			
	400	34.13 (867)	48.69 (1237)	55.56 (1411)			
	600	34.13 (867)	49.44 (1256)	56.19 (1427)			
16 (400)	150	37.63 (956)	52.94 (1344)	57.94 (1472)	26 (660)	3.5 (88.9)	
	300	37.63 (956)	53.25 (1352)	59 (1499)			
	400	37.63 (956)	53.5 (1359)	59.75 (1518)			
	600	37.63 (956)	53.5 (1359)	60.75 (1543)			
	900	38.13 (968)	55.25 (1403)	64 (1626)		4 (101.6)	
18 (450)	150	36.75 (933)	53.13 (1349)	58.63 (1489)	28 (711)	4 (101.6)	
	300	36.75 (933)	53.13 (1349)	59.38 (1508)			
	400	36.75 (933)	53.75 (1365)	60.5 (1537)			
	600	36.75 (933)	54.75 (1391)	62.25 (1581)			
20 (500)	150	38.13 (968)	54.63 (1387)	60.31 (1532)	30 (762)	4 (101.6)	
	300	38.13 (968)	55.38 (1406)	61.75 (1568)			
	400	38.13 (968)	56.13 (1425)	63 (1600)			
	600	38.13 (968)	54.69 (1389)	62.44 (1586)			
24 (600)	150	40.38 (1026)	59.88 (1521)	65.88 (1673)	36 (914)	3 (76.2)	
	300	41.63 (1057)	62.5 (1587)	69.13 (1756)			
	400	43.5 (1105)	65 (1651)	72.13 (1832)			
	600	44.75 (1137)	66.25 (1683)	74.5 (1892)			

Inch
(millimeter)

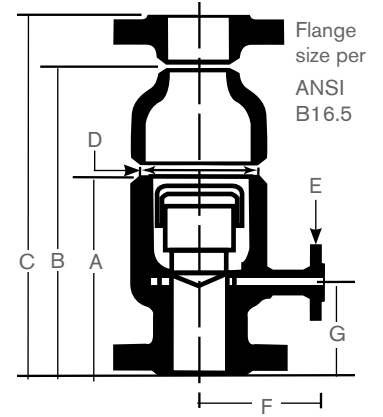

Typical Fabricated Arrangement

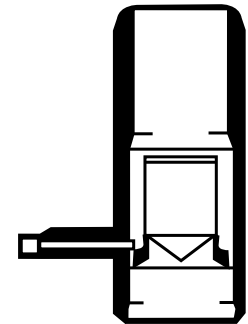

Please contact Copes-Vulcan for F and G dimensions.

A VO-76 typically will be one nominal size smaller than the equivalent VO-II. Both will have the same size plug and internal components.

Request available pressure/temperature ratings and dimensions.

Note: All dimensions are subject to change without notice.
Request certified drawings.



Global locations

SPX FLOW TECHNOLOGY

5620 West Road
McKean, PA 16426
United States of America
+1 814 476 5800

SPX FLOW TECHNOLOGY

Road Two, Industrial Estate
Winsford, Cheshire CW7 3QL
England
+44 1606 552041

SPX FLOW TECHNOLOGY

25 International Business Park
#03-03/12 German Centre
Singapore 609916
+65 6264 4366

SPX FLOW TECHNOLOGY

6F Treasury Building
1568 Hua Shan Road
Shanghai 200052
PR China
+86 21 2208 5888

Based in Charlotte, North Carolina, SPX Corporation (NYSE: SPW) is a global Fortune 500 multi-industry manufacturing leader. For more information, please visit www.spx.com

SPX FLOW TECHNOLOGY

5620 West Rd.
McKean, PA 16426
P: (814)476-5800
F: (814)476-5854
E: cv@spx.com

SPX reserves the right to incorporate our latest design and material changes without notice or obligation.

Design features, materials of construction and dimensional data, as described in this bulletin, are provided for your information only and should not be relied upon unless confirmed in writing. Please contact your local sales representative for product availability in your region. For more information visit www.spx.com.

The green ">" is a trademark of SPX Corporation, Inc.

ISSUED 03/2012 CV-1147-US

COPYRIGHT © 2012 SPX Corporation