



ProPOS Series Low Pressure Rupture Disk Assemblies

ZOOK ProPOS Rupture Disk is a bi-directional rupture disk designed to prevent over-pressurization and provide vacuum protection for processing and storage tanks. The assembly design allows ultra low-pressure relief in the positive direction (starting at 1" of water column differential). The assembly may be specified to protect equipment in the vacuum direction (up to full vacuum).

HOW ProPOS WORKS:

POSITIVE PRESSURE RELIEF

Controlled by the Girdle

As the pressure in the system approaches the positive burst setting, the seal presses against the girdle, deflecting it towards the knife blades built into the outlet holder. As the girdle passes the knife blades, the seal is cut relieving the POSITIVE pressure. The laser cut holes in the Burst Cap or Pressure Cap provide optimum flow when the rupture disk relieves in the positive pressure direction.

VACUUM RELIEF

Controlled by Metal Top Section

The Burst Cap, under tension loading, relieves negative (vacuum) pressure when vacuum occurs in the system.

ProPOS Components:

- **GIRDLE**
Standard material is 316SS. Also available in PTFE. The girdle controls the standard min. to max. inches of water column positive pressure rating
- **SEAL**
Evenly distributes pressure in both the positive and vacuum pressure direction
- **PROTECTIVE RING**
Provides seat area protection for seal on applications that do not require negative (vacuum) pressure relief

(OPTIONAL/INTERCHANGEABLE COMPONENTS)



OPTIONS

- **LASER CUT PRESSURE CAP***
Provides protection to seal in case of negative (vacuum) pressure
- **LASER CUT BURST CAP***
Provides negative (vacuum) pressure relief at specified rating

*This option will significantly reduce the flowing capacities in the Positive pressure relief direction. Contact ZOOK for flow rate information.

Features

- Highly accurate, ultra-low burst pressures available
- Dual-Acting, tension loaded design, with laser cut metal top section and girdle (when ordered in 316SS)
- Sizes 3" thru 12"
- 316SS or PTFE girdle material available
- Flat seat design
- Burst ratings from 1" of water column to 150 psig
- Temperature ratings to 500°F (260°C)
- 3-dimensional stainless steel tag is standard

Option

- Burst indication

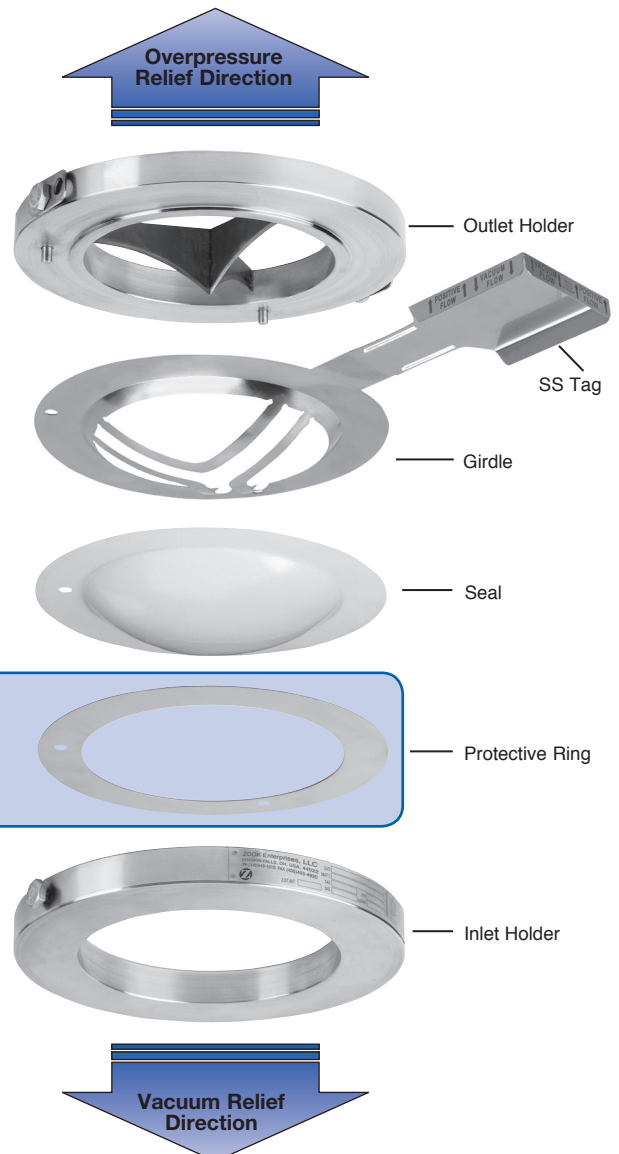

Table 1 – ProPOS Series Minimum and Maximum Pressure Ratings – psig (bar) @72°F (22°C)

Disk Size	Vacuum Relief		Positive Pressure Relief		Full Relief Rating (maximum) inches of water column with 316SS Girdle
			Start Relief Rating (minimum) inches of water column	316SS Girdle	
	min.	max.	min.		
3"	8	150	1	30	Plus (+) 6 inches of water column from start of relief (minimum rating)
80 mm	0.55	10.3			
4"	7	125	1	30	
100 mm	0.48	8.62			
6"	4	100	1	30	
150 mm	0.28	6.89			
8"	3	75	1	30	
200 mm	0.21	5.17			
10"	3	50	6	30	
250 mm	0.21	3.45			
12"	2	40	6	30	
300 mm	0.14	2.76			
Max. Temp.	500°F (260°C)				

Note: Contact ZOOK for girdle details if required.

Table 2 – ProPOS Series Disk with Burst Cap rated for negative (vacuum) pressure – Manufacturing Range/Burst Tolerance

Specified Burst Pressure Rating psig (bar)	Manufacturing Range		Burst Tolerance
	% under	% over	
2 to below 5 (0.138 to below 0.34)	-40	+40	± 25%
5 to below 8 (0.34 to below 0.55)	-40	+40	± 20%
8 to below 12 (0.55 to below 0.83)	-30	+30	± 15%
12 to below 14 (0.83 to below 0.97)	-10	+20	± 10%
14 to below 19 (0.97 to below 1.31)	-10	+20	± 2 psi (± 0.14)
19 to below 39 (1.31 to below 2.69)	-4	+14	± 2 psi (± 0.14)
39 to below 50 (2.69 to below 3.45)	-4	+14	± 5%
50 to below 100 (3.45 to below 6.89)	-4	+10	± 5%
100 to below 150 (6.89 to below 10.30)	-4	+7	± 5%

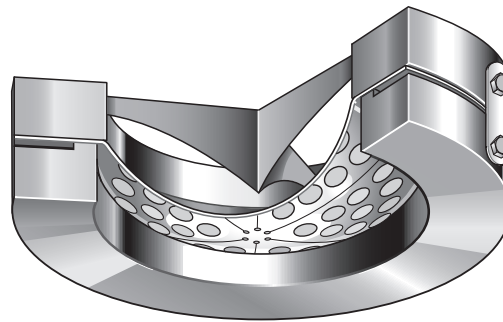

ProPOS Series Disk Holder

Features

- Insert type Rupture Disk Holder – designed exclusively to be used with the ProPOS Series Rupture Disk
- Non-torque sensitive flat seal design
- The ProPOS Holder and Rupture Disk are assembled using safety designed side clips
- Standard materials of construction: 316SS and carbon steel. Other materials available upon request
- Permanently attached stainless steel nameplates are standard. Nameplates indicate flow direction and provide visual verification that holder assembly is properly oriented in the piping system

Holder Dimensions – Inches (mm)

Nominal Size	ASME B16.5 Flange Classes ■	Height
	Class 150 O.D.	
3"	5-1/4"	1-1/4"
80 mm	133.35	31.75
4"	6-3/4"	1-1/4"
100 mm	171.45	31.75
6"	8-5/8"	1-1/4"
150 mm	219.08	31.75
8"	10-7/8"	1-3/8"
200 mm	276.23	34.93
10"	13-1/4"	1-3/4"
250 mm	336.55	44.45
12"	16"	1-3/4"
300 mm	406.40	44.45

■ Available to fit DIN and JIS flanges
Contact ZOOK for alternate flange class ratings



ZOOK Enterprises, LLC
16809 Park Circle Drive
Chagrin Falls, OH 44022 U.S.A.
Toll Free **800.543.1043**
Phone **440.543.1010**
Fax **440.543.4930**
E-mail **sales@zook.cc**

ZOOK Canada, Inc.
4400 South Service Road
Burlington, ON Can. L7L 5R8
Toll Free **800.370.6057**
Phone **905.681.2885**
Fax **905.681.8838**
E-mail **sales.canada@zook.cc**

ZOOK Europe, LTD.
Navigation House, Bridge Street
Killamarsh, Sheffield UK. S21 1AL
Phone **0044 (0) 1909 560999**
Fax **0044 (0) 1909 560860**
E-mail **zookeurope@zook.cc**

visit us on the web at www.zook.cc