

Screw Type – ST Series Holder

- Designed for use with PBST, FPB, DST or FD Series Rupture Disks
- Available in Standard 30° angle or flat seat designs
- Ideal for application pressures up to 15,000 psig
- Standard materials of construction: 300 series stainless steel. Other materials are available, contact ZOOK
- Standard inlet connections: 1/4" MNPT or 1/2" MNPT
- Standard outlet connections: muffled*, free (open to atmosphere) or threaded
- Standard unit consists of 3 components: Inlet, Hold-down Ring and Outlet. The rupture disk mounts between the inlet and the hold-down ring. The outlet nut provides compression required to seal the disk
- ASME UD marking is available upon request
Contact ZOOK for more information

*Muffled outlets reduce noise levels and redirect fragments or product released when the rupture disk bursts

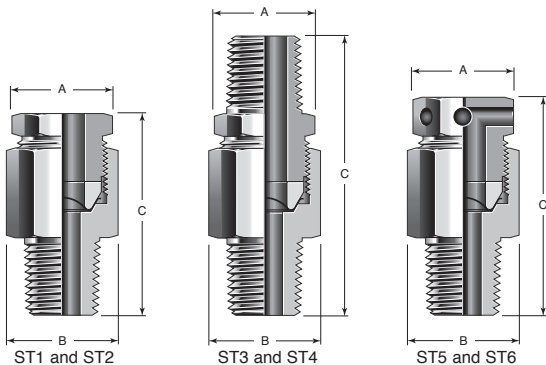

Assembly Number	Connections		Hex Size		Approximate end-to-end dimensions C
	INLET	OUTLET	A	B	
ST1	1/4" MNPT	FREE	1-1/8"	1-1/4"	2-3/8"
ST2	1/2" MNPT	FREE	1-1/8"	1-1/4"	2-3/8"
ST3	1/4" MNPT	1/2" MNPT	1-1/8"	1-1/4"	3-3/16"
ST4	1/2" MNPT	1/2" MNPT	1-1/8"	1-1/4"	3-3/16"
ST5	1/4" MNPT	MUFFLED	1-1/8"	1-1/4"	2-9/16"
ST6	1/2" MNPT	MUFFLED	1-1/8"	1-1/4"	2-9/16"

1.) 1/2" Angle Seated Hold-down rings are hardened Stainless Steel

Seat / Size based on pressure:

Min – 1,000 psi: 11/16" flat
 1,000 – 3,000 psi: 1/2" angle
 3,000 – 15,000 psi: 1/2" flat

Refer to PB or D series rupture disk product bulletins for additional information

Bulletin no. 321650
 © 2012 ZOOK Enterprises, LLC, all rights reserved
 Printed in U.S.A. 12-12-1500-CGG



ZOOK Enterprises, LLC
 16809 Park Circle Drive
 Chagrin Falls, OH 44022 U.S.A.
 Toll Free **800.543.1043**
 Phone **440.543.1010**
 Fax **440.543.4930**
 E-mail **sales@zook.cc**

ZOOK Canada, Inc.
 4400 South Service Road
 Burlington, ON Can. L7L 5R8
 Toll Free **800.370.6057**
 Phone **905.681.2885**
 Fax **905.681.8838**
 E-mail **sales.canada@zook.cc**

ZOOK Europe, LTD.
 Navigation House, Bridge Street
 Killamarsh, Sheffield UK. S21 1AL
 Phone **0044 (0) 1909 560999**
 Fax **0044 (0) 1909 560860**
 E-mail **zookeurope@zook.cc**