



# ProVAC Series Low Pressure Rupture Disk Assemblies

ZOOK ProVAC Rupture Disk is a bi-directional rupture disk designed to provide vacuum protection and prevent over-pressurization for processing and storage tanks.

The assembly design allows ultra low-pressure relief in the vacuum direction (starting at 1" of water column differential). The assembly may be specified to protect equipment from overpressurization.

### HOW ProVAC WORKS:

#### VACUUM RELIEF

##### *Controlled by the Girdle*

As the pressure in the system approaches the vacuum burst setting, the seal presses against the girdle, deflecting it towards the knife blades built into the inlet holder. As the girdle passes the knife blades, the seal is cut relieving the negative (vacuum) pressure. The laser cut holes in the Burst Cap or Pressure Cap provide optimum flow when the rupture disk relieves in the negative (vacuum) direction.

#### POSITIVE PRESSURE RELIEF

##### *Controlled by Metal Top Section*

The Burst Cap, under tension loading, relieves positive pressure when pressurization occurs in the system.

### (OPTIONAL/INTERCHANGEABLE COMPONENTS)



Non opening Pressure Cap

Burst Cap

Protective Ring

#### ProVAC Components:

##### • PROTECTIVE RING

Provides seat area protection for seal on applications that do not require positive pressure relief

##### • SEAL

Evenly distributes pressure in both the vacuum and positive pressure direction

##### • GIRDLE

Standard material is 316SS. Also available in PTFE. The girdle controls the standard min. to max. inches of water column negative (vacuum) pressure rating

#### OPTIONS

##### • LASER CUT PRESSURE CAP\*

Provides protection to seal in case of positive pressure

##### • LASER CUT BURST CAP\*

Provides positive pressure relief at specified rating

\*This option will significantly reduce the flowing capacities in the vacuum relief direction. Contact ZOOK for flow rate information.

### Features

- Highly accurate, ultra-low burst pressures available
- Dual-Acting, tension loaded design, with laser cut metal top section and girdle (when ordered in 316SS)
- Sizes 3" thru 12"
- 316SS or PTFE girdle material available
- Flat seat design
- Burst ratings from 1" of water column to 150 psig
- Temperature ratings to 500°F (260°C)
- 3-dimensional stainless steel tag is standard

### Option

- Burst indication

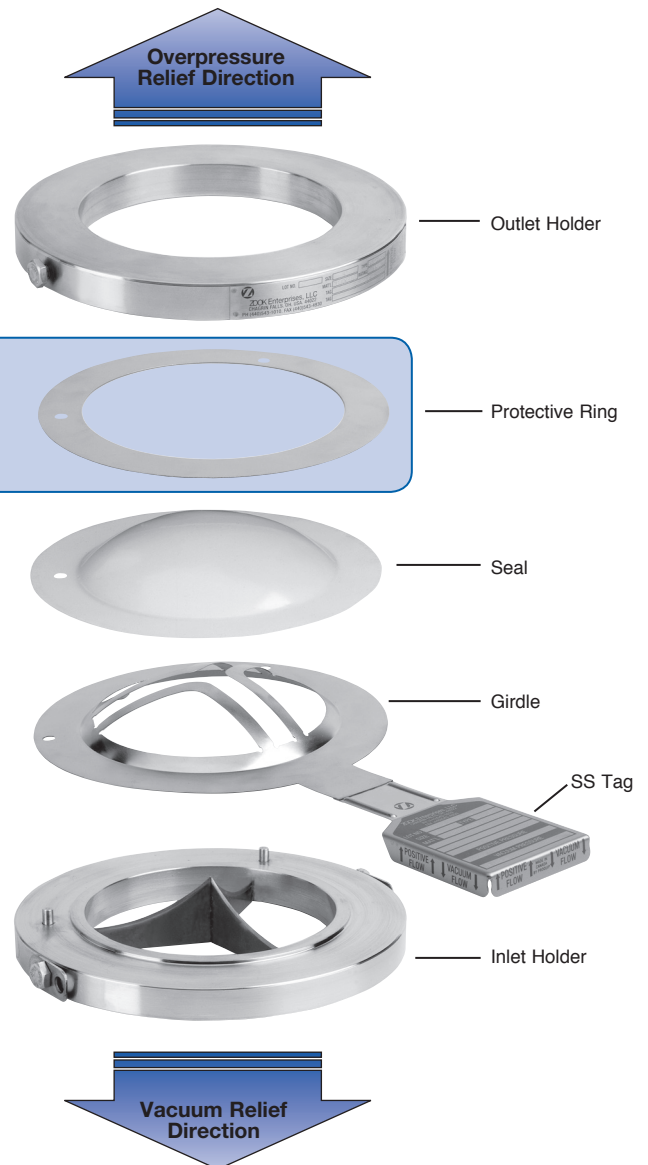

**Table 1** – ProVAC Series Minimum and Maximum Pressure Ratings – psig (bar) @72°F (22°C)

Disk Size	Positive Pressure Relief		Vacuum Relief		Full Relief Rating (maximum) inches of water column with 316SS Girdle
			Start Relief Rating (minimum) inches of water column		
			316SS Girdle		
	min.	max.	min.	max.	
3"	8	150	1	30	Plus (+) 6 inches of water column from start of relief (minimum rating)
80 mm	0.55	10.3			
4"	7	125	1	30	
100 mm	0.48	8.62			
6"	4	100	1	30	
150 mm	0.28	6.89			
8"	3	75	1	30	
200 mm	0.21	5.17			
10"	3	50	6	30	
250 mm	0.21	3.45			
12"	2	40	6	30	
300 mm	0.14	2.76			
Max. Temp.	500°F (260°C)				

Note: Contact ZOOK for girdle details if required.

**Table 2** – ProVAC Series Disk with Burst Cap rated for positive pressure – Manufacturing Range/Burst Tolerance

Specified Burst Pressure Rating psig (bar)	Manufacturing Range		Burst Tolerance
	% under	% over	
2 to below 5 (0.138 to below 0.34)	-40	+40	± 25%
5 to below 8 (0.34 to below 0.55)	-40	+40	± 20%
8 to below 12 (0.55 to below 0.83)	-30	+30	± 15%
12 to below 14 (0.83 to below 0.97)	-10	+20	± 10%
14 to below 19 (0.97 to below 1.31)	-10	+20	± 2 psi (± 0.14)
19 to below 39 (1.31 to below 2.69)	-4	+14	± 2 psi (± 0.14)
39 to below 50 (2.69 to below 3.45)	-4	+14	± 5%
50 to below 100 (3.45 to below 6.89)	-4	+10	± 5%
100 to below 150 (6.89 to below 10.30)	-4	+7	± 5%

# ProVAC Series Disk Holder

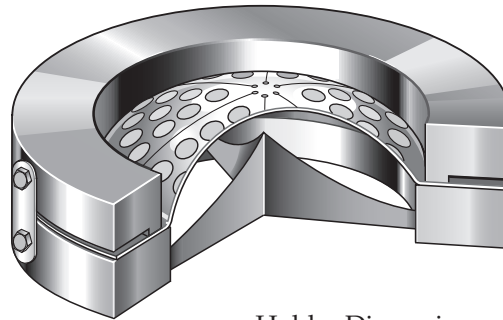

## Features

- Insert type Rupture Disk Holder – designed exclusively to be used with the ProVAC Series Rupture Disk
- Non-torque sensitive flat seal design
- The ProVAC Holder and Rupture Disk are assembled using safety designed side clips
- Standard materials of construction: 316SS and carbon steel. Other materials available upon request
- Permanently attached stainless steel nameplates are standard. Nameplates indicate flow direction and provide visual verification that holder assembly is properly oriented in the piping system

Holder Dimensions – Inches (mm)

Nominal Size	ASME B16.5 Flange Classes ■	Height
	Class 150 O.D.	
3"	5-1/4"	1-1/4"
80 mm	133.35	31.75
4"	6-3/4"	1-1/4"
100 mm	171.45	31.75
6"	8-5/8"	1-1/4"
150 mm	219.08	31.75
8"	10-7/8"	1-3/8"
200 mm	276.23	34.93
10"	13-1/4"	1-3/4"
250 mm	336.55	44.45
12"	16"	1-3/4"
300 mm	406.40	44.45

■ Available to fit DIN and JIS flanges  
Contact ZOOK for alternate flange class ratings



**ZOOK Enterprises, LLC**  
16809 Park Circle Drive  
Chagrin Falls, OH 44022 U.S.A.  
Toll Free **800.543.1043**  
Phone **440.543.1010**  
Fax **440.543.4930**  
E-mail **sales@zook.cc**

**ZOOK Canada, Inc.**  
4400 South Service Road  
Burlington, ON Can. L7L 5R8  
Toll Free **800.370.6057**  
Phone **905.681.2885**  
Fax **905.681.8838**  
E-mail **sales.canada@zook.cc**

**ZOOK Europe, LTD.**  
Navigation House, Bridge Street  
Killamarsh, Sheffield UK. S21 1AL  
Phone **0044 (0) 1909 560999**  
Fax **0044 (0) 1909 560860**  
E-mail **zookeurope@zook.cc**

visit us on the web at [www.zook.cc](http://www.zook.cc)