

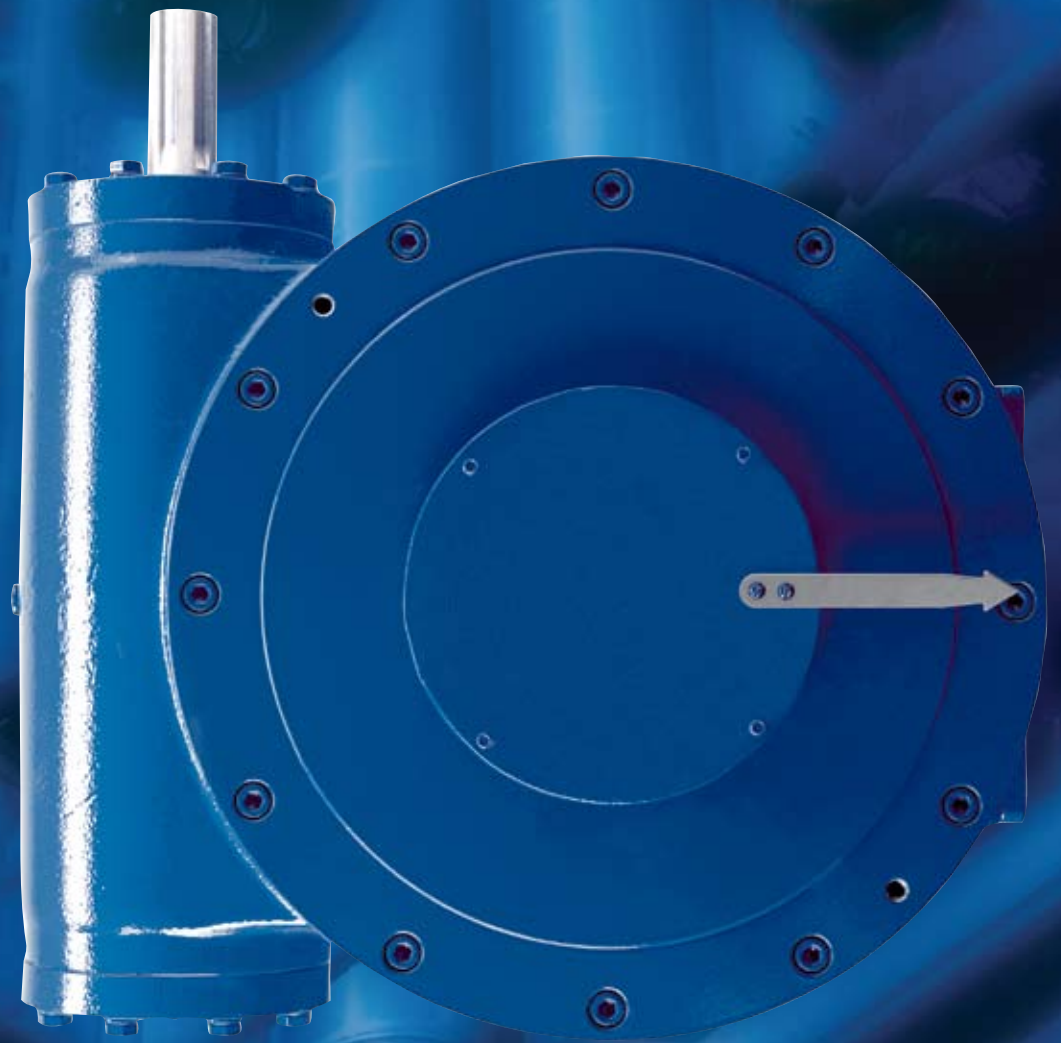

Limitorque HBC Series Worm Gear Operators

Proven in the most demanding situations



Experience In Motion



***Flowserve Limitorque HBC Series:
A worm gear drive capable of manual or motorized operation***



Limitorque's HBC series worm gear operators excel in diverse applications. Their dependability has been proven in the most demanding situations, ranging from nuclear power plants, to large damper operations, to power plant flue gas desulphurization. Equipped with a handwheel, the HBC can be used to manually operate butterfly, plug, and ball valves. Combined with a Limitorque electric actuator (such as the SMB, L120, or MX), the HBC provides powerful and responsive motorized operation. These combination actuators provide a wide range of output speeds and output torques to 93,000 ft-lb (126,100 N m). HBC operators feature an optional 360° worm gear for use in guillotine damper and radial gate applications. Whether manual or motorized, depend on the HBC for easy valve control — even in tough installations.



HBC – over 40 years of proven effectiveness in a wide range of applications, including:

Nuclear and fossil fuel power generation

The HBC has been successfully tested in conjunction with the SMB electric actuator to IEEE standards for environmental and seismic conditions for nuclear plant service. Whether inside containment in safety-related applications or installed on flue gas desulphurization systems or large diameter butterfly valves in fossil fuel power plants, the rugged and reliable HBC delivers outstanding performance year in and year out.

Petroleum refining and transmission

HBCs are at work in these quarter-turn valve applications, providing consistent, worry-free operation. In the plant or on pipelines in any climate, the HBC is suited to a broad range of service conditions and temperatures from extreme cold to the desert heat.

Water and wastewater treatment

HBC worm gear operators are found in these applications where specifications demand a product with a long history of dependable operation under severe and critical service conditions. The demonstrated excellence in design and functionality make the HBC the operator of choice when nothing less than proven reliability is required.

The HBC provides key advantages for quarter-turn actuation

- Enables manual operation
- Adapts multi-turn actuators to quarter-turn applications
- Covers a wide variety of output speeds and torques

Spur gear attachments increase your options

The HBC can be equipped with an optional spur gear attachment to further reduce input torque requirements—making it possible to operate even high-torque valves with a handwheel. Motorized applications can also incorporate spur gear attachments to reduce input torque requirements, allowing the use of smaller, less costly actuators to operate the valves.

To achieve specific operating/stroke times, please inquire about alternate spur gear ratios that are available for many larger valve applications.

Expand control capabilities with motorized operation

The HBC can easily handle valve positioning and modulating tasks when matched with a Limitorque electric actuator such as the L120, SMB or MX.

The HBC is used not only in quarter-turn applications, but can be provided with a 360° output for use with manually operated and motorized multi-turn devices such as guillotine dampers and radial gates.

Anatomy of the HBC Series

The HBC manual operator has an alloy steel worm shaft and a bronze worm gear. Buried and submersible operators are equipped with non-corrosive input shafts.

On all operators, except for buried service, a valve position pointer is provided as a standard feature. Handwheels are optional and can be furnished in various sizes.

All operator sizes can be supplied with factory-mounted Limitorque electric valve actuators or can be readily converted to motor operation in the field using Limitorque electric actuators.

The speed of operation for butterfly, plug, or ball valves when motor-operated can be varied over a broad range, limited only by motor speed and available gear ratios.

All HBCs are built to meet AWWA requirements. AWWA input limit stops are available for non-motorized applications.

HBC-4 through -7

Valve position pointer makes it easy to check position at a glance.

Bronze worm gear teams with an alloy steel worm shaft for rugged reliability.

Strong cast-iron housing—tough enough to withstand buried and submersible service applications.

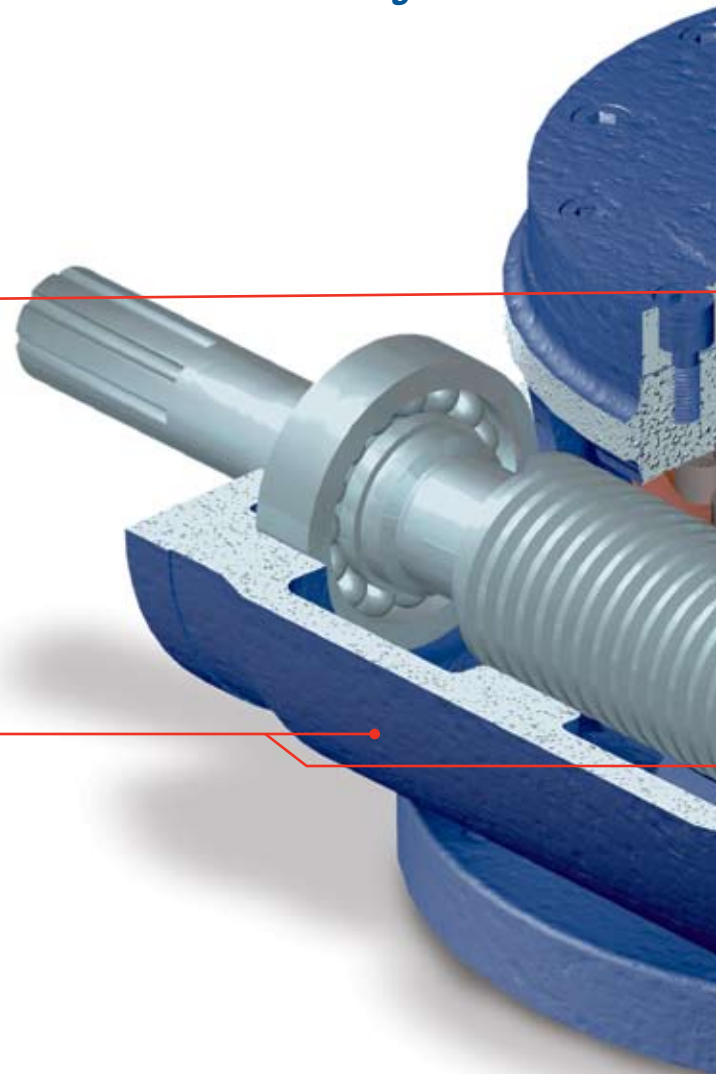



HBC-0 through -3
with optional handwheel

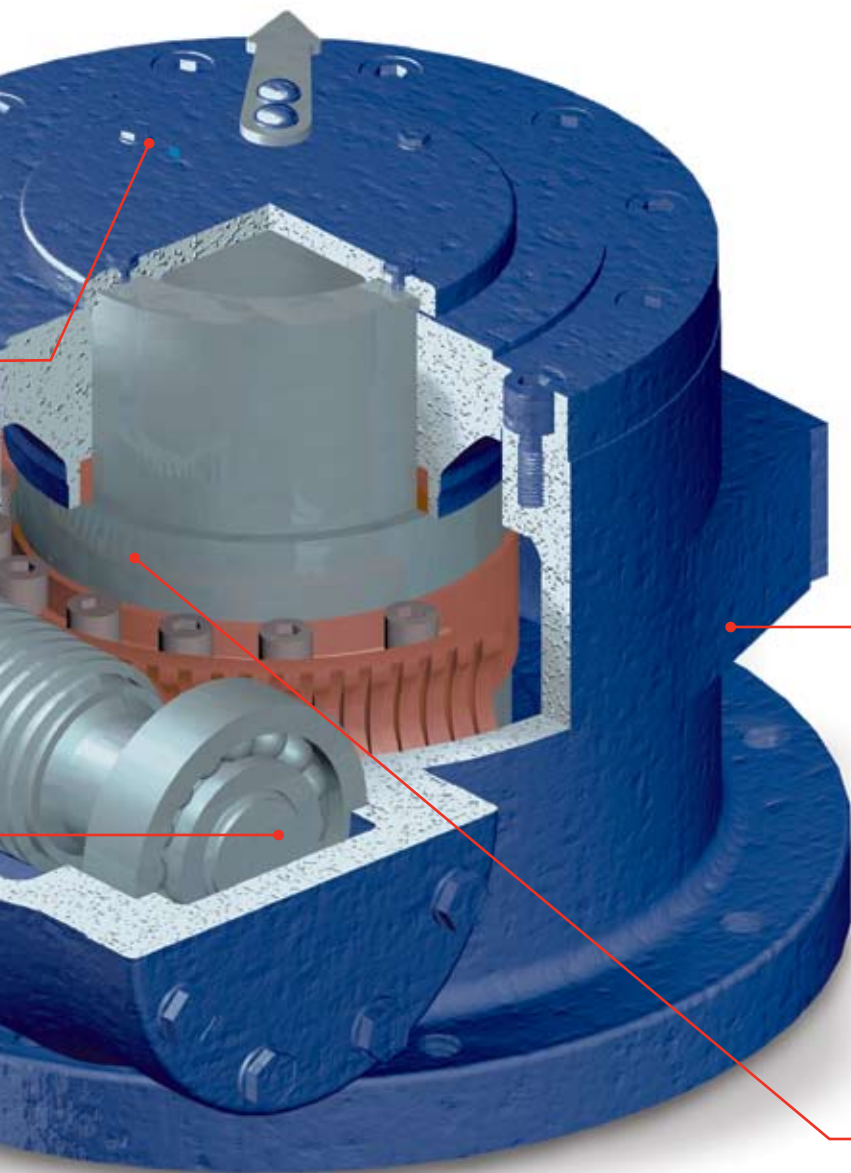

*Adjustable mechanical stop
enables users to accurately set
valve travel limit.*

*Rotating components supported by
low-friction bearings.*



Combines with Limitorque electric actuators for enhanced capabilities:

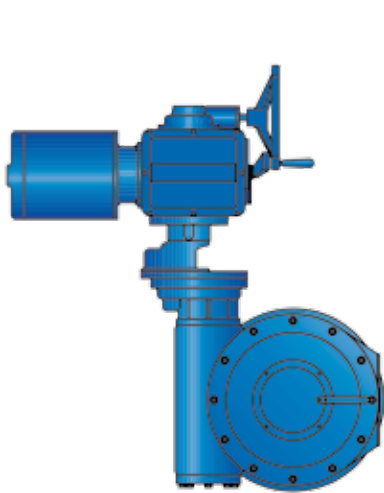

HBC-5/SGA/SMB-00

(All SMB actuators can be mounted to the HBC manual operators.)



HBC-3/SGA/L120-20

(All L120 actuators can be mounted to the HBC manual operators.)



HBC-3/MX-10

(All MX actuators can be mounted to the HBC manual operators.)

HBC-0 through -7 standard operator dimensions

Top view

Assembly position **B** (CW input producing CW output) (See **Note 1**)

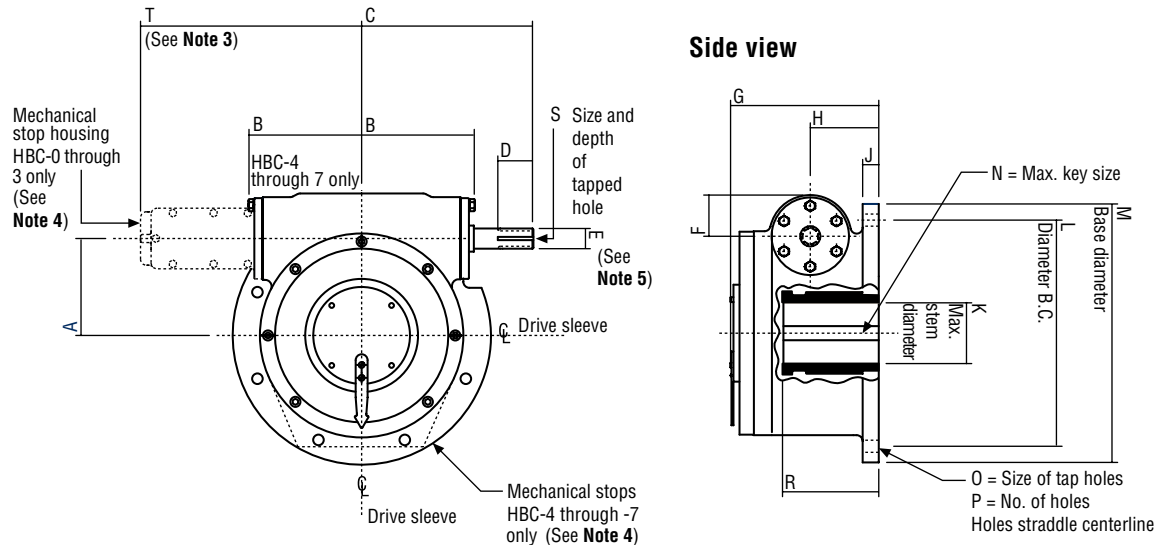

Note 1: Position A is standard for HBC-7 due to left-hand gearing.

Note 2: See certification sheet if position A is supplied.

Note 3: Mechanical stop housing HBC-0 through -3 only.

Note 4: External stops on worm shaft on HBC-0, -1, -2 and -3 only.
HBC-4, -5, -6 and -7 have stops on drive sleeve.

Note 5: See input shaft spline chart on page 8.

Alternate assembly position **A** (CCW input producing CW output) (See **Notes 2 and 3**)

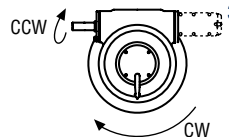

Dimensions in inches

	A	B	C	D	E ⁵	F	G	H	J	K	L	M	N	O	P	R	S	T
HBC-0	2.5	4.6	7.1	1.6	1.0	2.1	6.8	3.0	0.8	1.50	8.25	9.5	3/8 x 1/4	1/2-13	8	3.1	3/8-16 x 0.8	9.9
HBC-1	3.5	5.4	8.6	2.0	1.25	2.5	8.1	3.6	0.8	1.88	10.00	11.4	1/2 x 3/8	5/8-11	8	4.4	3/8-16 x 0.8	11.9
HBC-2	4.3	5.9	9.3	2.0	1.25	2.7	8.4	3.8	1.0	2.88	11.75	13.5	3/4 x 1/2	3/4-10	8	5.3	3/8-16 x 0.8	12.4
HBC-3	6.0	7.3	10.6	2.0	1.25	2.7	9.6	4.1	1.0	3.75	14.00	16.0	7/8 x 5/8	3/4-10	8	6.0	3/8-16 x 0.8	13.8
HBC-4	7.8	9.3	13.3	3.0	1.75	3.9	10.8	4.8	1.0	4.25	16.00	18.8	1 x 3/4	3/4-10	8	7.8	3/8-16 x 0.8	-
HBC-5	9.8	10.2	14.3	3.0	1.75	3.9	11.6	5.0	1.0	6.50	18.38	21.0	1 1/2 x 1	3/4-10	8	8.8	3/8-16 x 0.8	-
HBC-6	13.0	13.4	18.8	4.0	2.415	4.5	13.8	6.5	1.8	7.50	23.00	26.3	1 3/4 x 1 1/4	1 1/4-7	8	10.5	1/2-13 x 0.8	-
HBC-7/7M	16.0	15.1	19.3	4.0	2.75	5.4	14.1	6.3	2.5	9.00	29.00	31.8	1 3/4 x 1 1/4	1 1/4-7	8	8.9	1/2-13 x 1	-

Dimensions in millimeters

	A	B	C	D	E ⁵	F	G	H	J	K	L	M	N	O	P	R	S	T
HBC-0	64	118	180	41	25	52	173	76	19	38	210	241	10 x 8	1/2-13	8	79	3/8-16 x 0.8	252
HBC-1	89	138	219	51	32	64	205	92	19	48	254	289	14 x 9	5/8-11	8	111	3/8-16 x 0.8	302
HBC-2	108	151	235	51	32	68	214	95	25	73	299	343	20 x 12	3/4-10	8	134	3/8-16 x 0.8	314
HBC-3	152	186	270	51	32	68	243	105	25	95	356	406	25 x 14	3/4-10	8	152	3/8-16 x 0.8	349
HBC-4	197	237	337	76	45	98	275	121	25	108	406	476	28 x 16	3/4-10	8	197	3/8-16 x 0.8	-
HBC-5	248	259	362	76	45	98	294	127	25	165	467	533	40 x 22	3/4-10	8	222	3/8-16 x 0.8	-
HBC-6	330	340	476	102	61	114	351	165	45	191	584	667	45 x 25	1 1/4-7	8	267	1/2-13 x 0.8	-
HBC-7/7M	406	384	489	102	70	137	359	159	64	229	737	810	50 x 28	1 1/4-7	8	225	1/2-13 x 1	-

Note: The HBC-0 through HBC-6 operators are supplied with removable splined adapters for the output drive sleeve. The HBC-7 and HBC-7M operators are supplied with a bore and keyway-machined drive sleeve as standard, but with splined adapters available as an option. The maximum allowable bore diameter for the HBC-7 and HBC-7M splined adapters is less than that for the machined drive sleeves. Please contact the factory for allowable bore and keyway dimensions.

HBC-1 through -3 with optional spur gear attachment

Top view

Side view

Position B (CW input producing CW output)

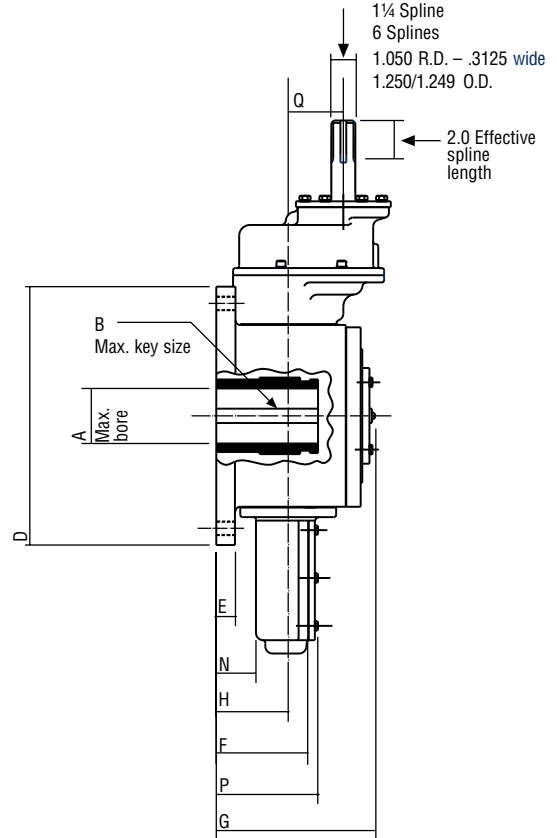
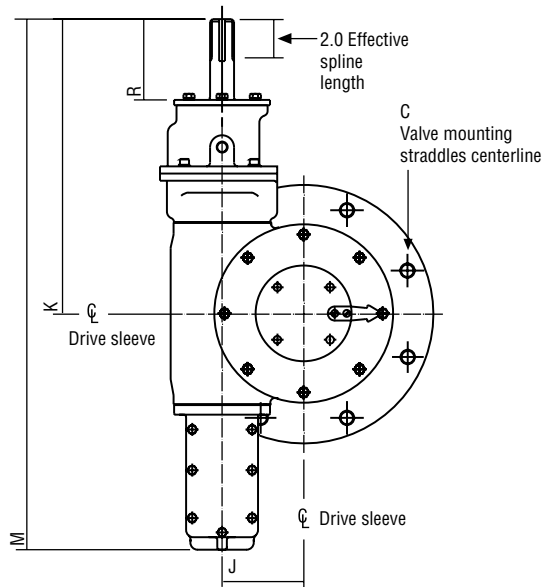

Alternate assembly position A (CCW input producing CW output) (See Note 1)

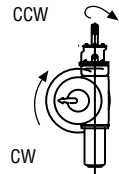

Note 1: See certification sheet if position A is supplied.

Dimensions in inches

	SGA	A	B	C	D	E	F	G	H	J	K	M	N	P	Q	R
HBC-1	2.86:1	1.88	1/2 x 3/8 x 4 3/8	(8) 5/8-11 x 0.8" DP on 10.0" BC	11.4	0.8	4.4	8.1	3.6	3.5	14.9	26.2	1.9	5.1	2.9	4.2
HBC-2	2.86:1	2.88	3/4 x 1/2 x 5 1/4	(8) 3/4-10 x 1.0" DP on 11.75" BC	13.5	1.0	5.3	8.4	3.8	4.3	15.4	27.8	2.1	5.3	2.9	4.2
HBC-3	2.86:1	3.75	7/8 x 5/8 x 6	(8) 3/4-10 x 1.0" DP on 14.0" BC	16.0	1.0	6.0	9.6	4.1	6.0	16.8	30.6	2.4	5.6	2.9	4.2

Dimensions in millimeters

	SGA	A	B	C	D	E	F	G	H	J	K	M	N	P	Q	R
HBC-1	2.86:1	47.8	13 x 10 x 111	(8) 5/8-11 x 0.8" DP on 10.0" BC	282	19	112	206	91	89	378	665	48	130	74	107
HBC-2	2.86:1	73.2	19 x 13 x 133	(8) 3/4-10 x 1.0" DP on 11.75" BC	343	25.4	135	213	97	109	391	706	53.3	135	74	107
HBC-3	2.86:1	95.3	22 x 16 x 152	(8) 3/4-10 x 1.0" DP on 14.0" BC	406	25.4	152	244	104	152	427	777	61	142	74	107

HBC-4 through -7 with optional spur gear attachment

Top view

Side view

Position B (CW input producing CW output) (See **Note 1**)

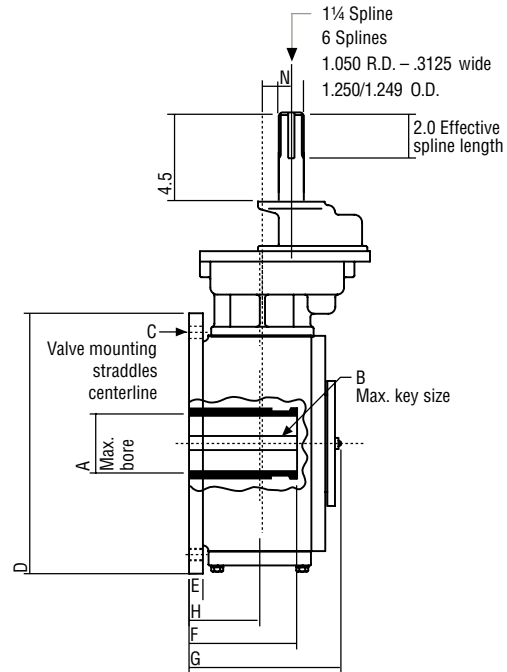
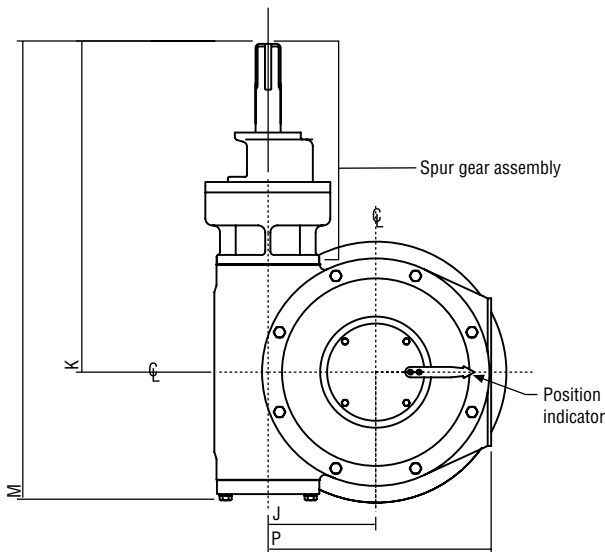

Alternate assembly position A (CCW input producing CW output) (See **Note 2**)

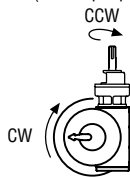

Note 1: Position A is standard for HBC-7M with 19.2:1 SGA (CW input, CW output).

Note 2: See certification sheet if position A is supplied.

Dimensions in inches

	SGA	A	B	C	D	E	F	G	H	J	K	M	N	P
HBC-4	6:1	4.29	1 x 3/4 x 7 3/4	(8) 3/4-10 x 1.3" DP on 16.0" BC	18.8	1.0	7.8	10.9	4.8	7.8	22.2	31.4	2.0	16.1
HBC-5	6:1	6.50	1 1/2 x 1 x 8 3/4	(8) 3/4-10 x 1.3" DP on 18.38" BC	21.0	1.0	8.8	11.6	5.0	9.8	23.1	33.2	2.0	19.8
HBC-6	13.6:1	7.52	1 3/4 x 1 1/4 x 10 1/2	(8) 1 1/4-7 x 1.8" DP on 23.0" BC	26.3	1.8	10.5	13.9	6.5	13.0	30.1	39.3	0.8	26.4
HBC-7/7M	19.2:1	9.02	2 1/2 x 1 3/4 x 11	(8) 1 1/4-7 x 1.8" DP on 29.0" BC	31.9	2.5	N/A*	14.2	6.3	16.0	31.4	46.4	0.8	29.3

Dimensions in millimeters

	SGA	A	B	C	D	E	F	G	H	J	K	M	N	P
HBC-4	6:1	109	28 x 16 x 197	(8) 3/4-10 x 1.3" DP on 16.0" BC	478	25	198	277	122	198	564	798	51	409
HBC-5	6:1	165	40 x 22 x 222	(8) 3/4-10 x 1.3" DP on 18.38" BC	533	25	224	295	127	249	587	843	51	503
HBC-6	13.6:1	191	45 x 25 x 267	(8) 1 1/4-7 x 1.8" DP on 23.0" BC	668	46	267	353	165	330	765	998	20	671
HBC-7/7M	19.2:1	229	50 x 28 x 280	(8) 1 1/4-7 x 1.8" DP on 29.0" BC	810	64	N/A*	361	160	406	798	1179	61	744

*Note: The HBC-0 through HBC-6 operators are supplied with removable splined adapters for the output drive sleeve. The HBC-7 and HBC-7M operators are supplied with a bore and keyway-machined drive sleeve as standard, but with splined adapters available as an option. The maximum allowable bore diameter for the HBC-7 and HBC-7M splined adapters is less than that for the machined drive sleeves. Please contact the factory for allowable bore and keyway dimensions.

General specifications

Operator/SGA	Ratio	Output torque rating		Input torque for output torque rating		Maximum one-time input torque	
		ft-lb	N m	ft-lb	N m	ft-lb	N m
HBC-0	71	445	605	21	28	100	136
HBC-1	70	1,300	1,764	62	84	600	814
HBC-1/S2.86	200	1,300	1,764	24	33	230	312
HBC-2	70	2,200	2,985	105	142	675	915
HBC-2/S2.86	200	2,200	2,985	41	56	260	353
HBC-3	70	5,650	7,667	269	365	510	692
HBC-3/S2.86	200	5,650	7,667	105	142	200	271
HBC-4	60	12,800	17,370	711	964	1,290	1,749
HBC-4/S6	360	12,800	17,370	132	179	240	325
HBC-5	65	19,583	26,575	1,004	1,361	1,830	2,481
HBC-5/S6	390	19,583	26,575	186	252	340	461
HBC-6	66	46,000	62,425	2,323	3,150	3,900	5,288
HBC-6/S13.6	898	46,000	62,425	205	278	319	433
HBC-7	69	63,333	85,945	3,060	4,149	6,600	8,950
HBC-7/S19.2	1,325	63,333	85,945	191	259	375	509
HBC-7M	50	93,000	126,204	6,200	8,407	10,000	13,560
HBC-7M/S19.2	960	93,000	126,204	388	526	613	831

Input shaft splines

Product	Input shaft splines (w/o SGAs)	Input shaft splines (w/ SGAs)
HBC-0	15 involute splines, 16/32 D.P., 0.9375" Pitch Dia.	Not Applicable
HBC-1, 2, 3	6 splines, 1.05" Root Dia., 0.310" wide, 1.250" O.D.	6 splines, 1.05" Root Dia., 0.310" wide, 1.250" O.D.
HBC-4, 5	6 splines, 1.525" Root Dia., 0.430" wide, 1.750" O.D.	6 splines, 1.05" Root Dia., 0.310" wide, 1.250" O.D.
HBC-6	28 involute splines, 12/24 D.P., 2.333" Pitch Dia.	6 splines, 1.05" Root Dia., 0.310" wide, 1.250" O.D.
HBC-7, 7M	3.750" dia., keyway 7/8 x 7/16 x 3.00" long	6 splines, 1.05" Root Dia., 0.310" wide, 1.250" O.D.

Approximate weights

Operator/SGA	Standard operator		With AWWA input stop	
	lb	kg	lb	kg
HBC-0	65	30	95	43
HBC-1	120	54	150	68
HBC-1/S2.86	160	73	190	86
HBC-2	150	68	180	82
HBC-2/S2.86	190	86	220	100
HBC-3	230	104	260	118
HBC-3/S2.86	270	123	300	136
HBC-4	465	211	495	225
HBC-4/S6	570	259	600	273
HBC-5	560	254	590	268
HBC-5/S6	665	302	695	316
HBC-6	1,600	726	1,630	741
HBC-6/S13.6	1,710	776	1,740	791
HBC-7	2,100	953	2,130	968
HBC-7/S19.2	2,375	1,078	2,405	1,093
HBC-7M	2,100	953	2,130	968
HBC-7M/S19.2	2,375	1,078	2,405	1,093

This page left intentionally blank.



**Flowserve Corporation
Flow Control**

United States

Flowserve Limatorque
5114 Woodall Road,
P.O. Box 11318
Lynchburg, VA 24506-1318
Phone: 434-528-4400
Facsimile: 434-845-9736

England

Flowserve Limatorque
Euro House
Abex Road
Newbury
Berkshire, RG14 5EY
United Kingdom
Phone: 44-1-635-46999
Facsimile: 44-1-635-36034

Japan

Limatorque – Nippon Gear Co., Ltd.
Asahi-Seimei Bldg. 4th Floor
1-11-11 Kita-Saiwai, Nishi-Ku
Yokohama-Shi, (220-0004)
Japan
Phone: 81-45-326-2065
Facsimile: 81-45-320-5962

Canada

Flowserve Limatorque
120 Vinyl Court
Woodbridge, Ontario L4L 4A3
Canada
Phone 905-856-4565
Fax 905-856-7905

Singapore

Limatorque Asia, Pte., Ltd.
12, Tuas Avenue 20
Singapore 638824
Phone: 65-6868-4628
Facsimile: 65-6862-4940

**To find your local Flowserve representative,
visit www.flowserve.com or call USA 1 800 225 6989**

FCD LMENBR3500-01 04/07 Printed in USA.

Flowserve Corporation has established industry leadership in the design and manufacture of its products. When properly selected, this Flowserve product is designed to perform its intended function safely during its useful life. However, the purchaser or user of Flowserve products should be aware that Flowserve products might be used in numerous applications under a wide variety of industrial service conditions. Although Flowserve can (and often does) provide general guidelines, it cannot provide specific data and warnings for all possible applications. The purchaser/user must therefore assume the ultimate responsibility for the proper sizing and selection, installation, operation, and maintenance of Flowserve products. The purchaser/user should read and understand the Installation Operation Maintenance (IOM) instructions included with the product, and train its employees and contractors in the safe use of Flowserve products in connection with the specific application.

While the information and specifications contained in this literature are believed to be accurate, they are supplied for informative purposes only and should not be considered certified or as a guarantee of satisfactory results by reliance thereon. Nothing contained herein is to be construed as a warranty or guarantee, express or implied, regarding any matter with respect to this product. Because Flowserve is continually improving and upgrading its product design, the specifications, dimensions and information contained herein are subject to change without notice. Should any question arise concerning these provisions, the purchaser/user should contact Flowserve Corporation at any one of its worldwide operations or offices.

© 2007 Flowserve Corporation, Irving, Texas, USA. Flowserve is a registered trademark of Flowserve Corporation.